

# UNS

油壓雙用



產品介紹：活塞和活塞桿雙用的密封件。大截面密封件可用於大範圍的壓力，有極好的耐磨性和密封能力。

主密封材料：聚氨酯（PU）

溫度範圍：-20~80度

壓力：350 bar / 加墊片 (BRT)：700 bar

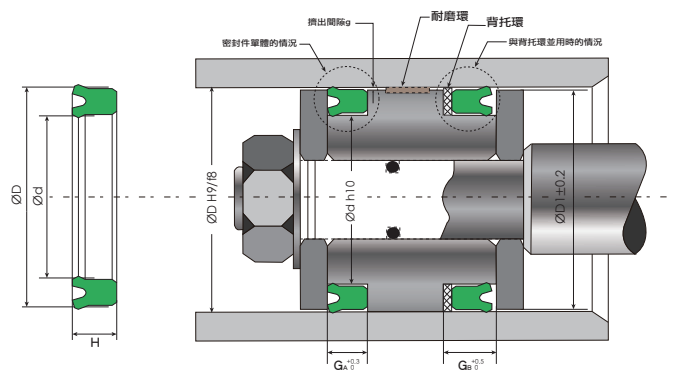
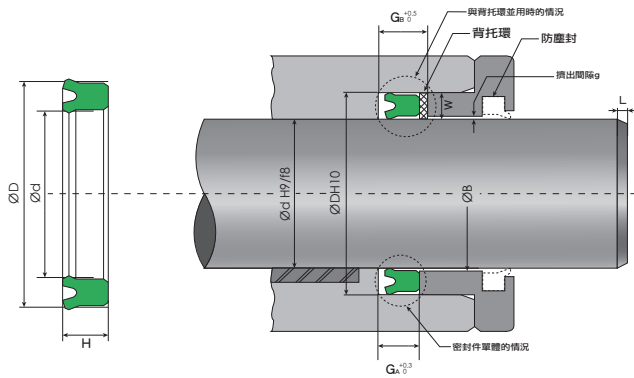

| 編號 Code No. | 內徑 d | 外徑 D | 高度 H |
|-------------|------|------|------|
| UNS-6.3     | 6.3  | 16.3 | 8    |
| UNS-7.1     | 7.1  | 17.1 | 8    |
| UNS-8       | 8    | 18   | 8    |
| UNS-9       | 9    | 19   | 8    |
| UNS-10      | 10   | 20   | 8    |
| UNS-11.2    | 11.2 | 21.2 | 8    |
| UNS-12.5    | 12.5 | 22.5 | 8    |
| UNS-14      | 14   | 24   | 8    |
| UNS-15      | 15   | 25   | 8    |
| UNS-16      | 16   | 26   | 8    |
| UNS-18      | 18   | 28   | 8    |
| UNS-20      | 20   | 30   | 8    |
| UNS-22.4    | 22.4 | 32.4 | 8    |
| UNS-25      | 25   | 35   | 8    |
| UNS-28      | 28   | 43   | 10.2 |
| UNS-30      | 30   | 45   | 10.2 |
| UNS-31.5    | 31.5 | 46.5 | 10.2 |
| UNS-35      | 35   | 50   | 10.2 |
| UNS-35.5    | 35.5 | 50.5 | 10.2 |

| 編號 Code No. | 內徑 d | 外徑 D | 高度 H |
|-------------|------|------|------|
| UNS-40      | 40   | 55   | 10.2 |
| UNS-45      | 45   | 60   | 10.2 |
| UNS-48      | 48   | 63   | 10.2 |
| UNS-50      | 50   | 65   | 10.2 |
| UNS-53      | 53   | 73   | 12   |
| UNS-55      | 55   | 75   | 12   |
| UNS-56      | 56   | 76   | 12   |
| UNS-60      | 60   | 80   | 12   |
| UNS-63      | 63   | 83   | 12   |
| UNS-65      | 65   | 85   | 12   |
| UNS-67      | 67   | 87   | 12   |
| UNS-70      | 70   | 90   | 12   |
| UNS-71      | 71   | 91   | 12   |
| UNS-75      | 75   | 95   | 12   |
| UNS-80      | 80   | 100  | 12   |
| UNS-85      | 85   | 105  | 12   |
| UNS-90      | 90   | 110  | 12   |
| UNS-95      | 95   | 115  | 12   |
| UNS-100     | 100  | 120  | 12   |







# UHS

油壓雙用



產品介紹：活塞和活塞桿雙用的橡膠密封件。較小截面的UNS，小截面密封件可裝入整體槽中。

主密封材料：聚氨酯（PU）

溫度範圍：-20~80度

壓力：210 bar / 加墊片 (BRT)：450 bar

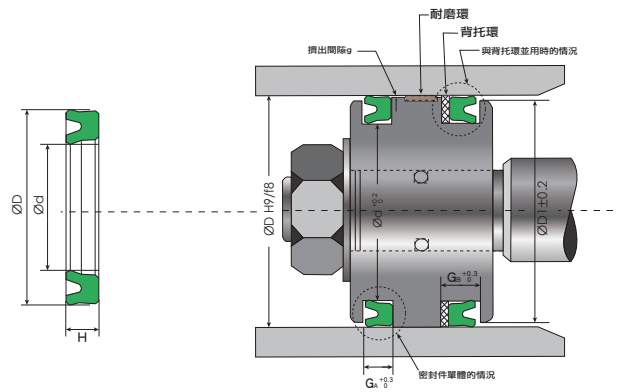
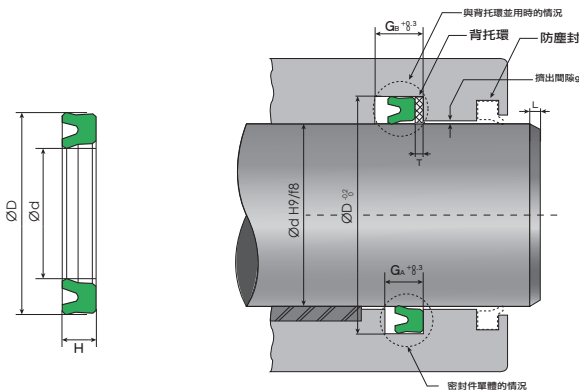

| 編號 Code No. | 內徑 d | 外徑 D | 高度 H |
|-------------|------|------|------|
| UHS-11.2    | 11.2 | 19.2 | 5    |
| UHS-14      | 14   | 22   | 5    |
| UHS-16      | 16   | 24   | 5    |
| UHS-18      | 18   | 26   | 5    |
| UHS-20      | 20   | 28   | 5    |
| UHS-22.4    | 22.4 | 30   | 5    |
| UHS-23.5    | 23.5 | 31.5 | 5    |
| UHS-25      | 25   | 33   | 5    |
| UHS-28      | 28   | 35.5 | 5    |
| UHS-30      | 30   | 40   | 6    |
| UHS-31.5    | 31.5 | 41.5 | 6    |
| UHS-35      | 35   | 45   | 6    |
| UHS-35.5    | 35.5 | 45   | 6    |
| UHS-38      | 38   | 48   | 6    |
| UHS-40      | 40   | 50   | 6    |
| UHS-45A     | 45   | 55   | 6    |
| UHS-45      | 45   | 56   | 7    |
| UHS-50      | 50   | 60   | 6    |
| UHS-53      | 53   | 63   | 6    |
| UHS-55      | 55   | 65   | 6    |
| UHS-56      | 56   | 66   | 6    |

| 編號 Code No. | 內徑 d | 外徑 D | 高度 H |
|-------------|------|------|------|
| UHS-58      | 58   | 68   | 6    |
| UHS-60A     | 60   | 70   | 6    |
| UHS-60      | 60   | 71   | 7    |
| UHS-63      | 63   | 73   | 6    |
| UHS-65      | 65   | 75   | 6    |
| UHS-67      | 67   | 77   | 6    |
| UHS-70      | 70   | 80   | 6    |
| UHS-71      | 71   | 80   | 6    |
| UHS-75      | 75   | 85   | 6    |
| UHS-80      | 80   | 90   | 6    |
| UHS-85      | 85   | 100  | 9    |
| UHS-90      | 90   | 105  | 9    |
| UHS-95      | 95   | 110  | 9    |
| UHS-98      | 98   | 112  | 9    |
| UHS-100     | 100  | 115  | 9    |
| UHS-112     | 112  | 125  | 9    |
| UHS-125     | 125  | 140  | 9    |
| UHS-136     | 136  | 150  | 9    |
| UHS-140     | 140  | 155  | 9    |
| UHS-145     | 145  | 160  | 9    |

# UHR

油壓內徑用

產品介紹：活塞桿專用的密封件。較小截面的 UNR，小截面密封件可裝入整體槽中。

主密封材料：聚氨酯 (PU)

溫度範圍：- 20~80 度

壓力：350 bar / 加墊片 (BRT)：700 bar

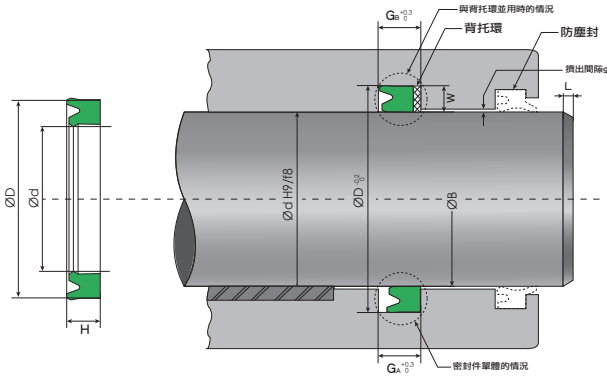

| 編號 Code No. | 內徑 d | 外徑 D | 高度 H |
|-------------|------|------|------|
| UHR-160     | 160  | 175  | 9.5  |
| UHR-165     | 165  | 180  | 9.5  |
| UHR-180     | 180  | 200  | 12.5 |
| UHR-200     | 200  | 220  | 12.5 |

| 編號 Code No. | 內徑 d | 外徑 D | 高度 H |
|-------------|------|------|------|
| UHR-18      | 18   | 26   | 5.2  |
| UHR-22.4    | 22.4 | 30   | 5.2  |
| UHR-28      | 28   | 35.5 | 5.2  |
| UHR-35.5    | 35.5 | 45   | 6.5  |
| UHR-40 特    | 40   | 50   | 6.5  |
| UHR-45A 特   | 45   | 55   | 6.5  |
| UHR-45      | 45   | 56   | 7.5  |
| UHR-50      | 50   | 60   | 6.5  |
| UHR-56      | 56   | 66   | 6.5  |
| UHR-63      | 63   | 73   | 6.5  |
| UHR-67      | 67   | 77   | 6.5  |
| UHR-71      | 71   | 80   | 6.5  |
| UHR-80      | 80   | 90   | 6.5  |
| UHR-85      | 85   | 100  | 9.5  |
| UHR-90      | 90   | 105  | 9.5  |
| UHR-100     | 100  | 115  | 9.5  |
| UHR-112     | 112  | 125  | 9    |
| UHR-125     | 125  | 140  | 9.5  |
| UHR-140     | 140  | 155  | 9.5  |





# DHS

油壓防塵用



產品介紹：防塵密封件，是一種防刮油雙唇口。防止粉塵進入、保護設備並保持密封性能的密封件，此密封件可裝入整體槽內。

主密封材料：聚氨酯（pu）

溫度範圍：-25 ~ 80 度

壓力：無

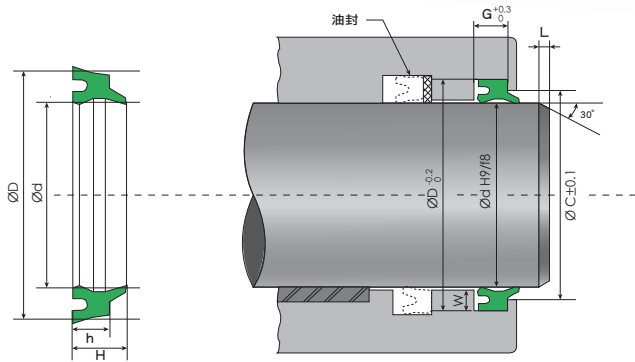

| 編號 Code No. | 內徑 d | 外徑 D | 高度 h | 高度 H |
|-------------|------|------|------|------|
| DHS-11.2    | 11.2 | 19.2 | 4.5  | 6    |
| DHS-14      | 14   | 22   | 4.5  | 6    |
| DHS-16      | 16   | 24   | 4.5  | 6    |
| DHS-18      | 18   | 26   | 4.5  | 6    |
| DHS-20      | 20   | 28   | 4.5  | 6    |
| DHS-22.4    | 22.4 | 30.4 | 4.5  | 6    |
| DHS-23.5    | 23.5 | 31.5 | 4.5  | 6    |
| DHS-25      | 25   | 33   | 4.5  | 6    |
| DHS-28      | 28   | 36   | 4.5  | 6    |
| DHS-30      | 30   | 38   | 5    | 6.5  |
| DHS-31.5    | 31.5 | 39.5 | 5    | 6.5  |
| DHS-35      | 35   | 43   | 5    | 6.5  |
| DHS-35.5    | 35.5 | 43.5 | 5    | 6.5  |
| DHS-40      | 40   | 48   | 5    | 6.5  |
| DHS-45      | 45   | 53   | 5    | 6.5  |
| DHS-50      | 50   | 58   | 5    | 6.5  |
| DHS-53      | 53   | 61   | 5    | 6.5  |
| DHS-55      | 55   | 63   | 5    | 6.5  |
| DHS-56      | 56   | 64   | 5    | 6.5  |

| 編號 Code No. | 內徑 d | 外徑 D | 高度 h | 高度 H |
|-------------|------|------|------|------|
| DHS-60      | 60   | 68   | 5    | 6.5  |
| DHS-63      | 63   | 71   | 5    | 6.5  |
| DHS-65      | 65   | 73   | 5    | 6.5  |
| DHS-67      | 67   | 75   | 5    | 6.5  |
| DHS-70      | 70   | 80   | 6    | 8    |
| DHS-71      | 71   | 81   | 6    | 8    |
| DHS-75      | 75   | 85   | 6    | 8    |
| DHS-80      | 80   | 90   | 6    | 8    |
| DHS-85      | 85   | 95   | 6    | 8    |
| DHS-90      | 90   | 100  | 6    | 8    |
| DHS-98      | 98   | 108  | 6    | 8    |
| DHS-100     | 100  | 110  | 6    | 8    |
| DHS-112     | 112  | 122  | 6    | 8    |
| DHS-125     | 125  | 138  | 7    | 9.5  |
| DHS-136     | 136  | 149  | 7    | 9.5  |
| DHS-140     | 140  | 153  | 7    | 9.5  |
| DHS-145     | 145  | 158  | 7    | 9.5  |
| DHS-160     | 160  | 174  | 7    | 9.5  |
| DHS-165     | 165  | 179  | 7    | 9.5  |
| DHS-180     | 180  | 194  | 7    | 9.5  |
| DHS-200     | 200  | 214  | 7    | 9.5  |
| DHS-204     | 204  | 218  | 7    | 9.5  |
| DHS-230     | 230  | 244  | 7    | 9.5  |
|             |      |      |      |      |
|             |      |      |      |      |
|             |      |      |      |      |