

公司簡介	P.2
常用橡膠特性與用途	P.4
O 環與工作壓力參考表	P.5
O 環線徑公差	P.5
O 環尺寸公差標準表	P.6
O 環與元件加工尺寸參考表	P.7
O 環損壞的狀況	P.8
O 環 P 規格	P.12
O 環 P 特殊規格	P.14
O 環 G 規格	P.15
O 環 G 特殊規格	P.16
O 環 AS-568 規格	P.17
O 環 S 規格	P.22
O 環 V 規格	P.23
O 環 1m/m 規格	P.26
O 環 1.5m/m 規格	P.27
O 環 2m/m 規格	P.28
O 環 2.5m/m 規格	P.29
O 環 3m/m 規格	P.30
O 環 4m/m 規格	P.32
O 環 5m/m 規格	P.34
O 環 JASO 規格	P.35
X 型環	P.37

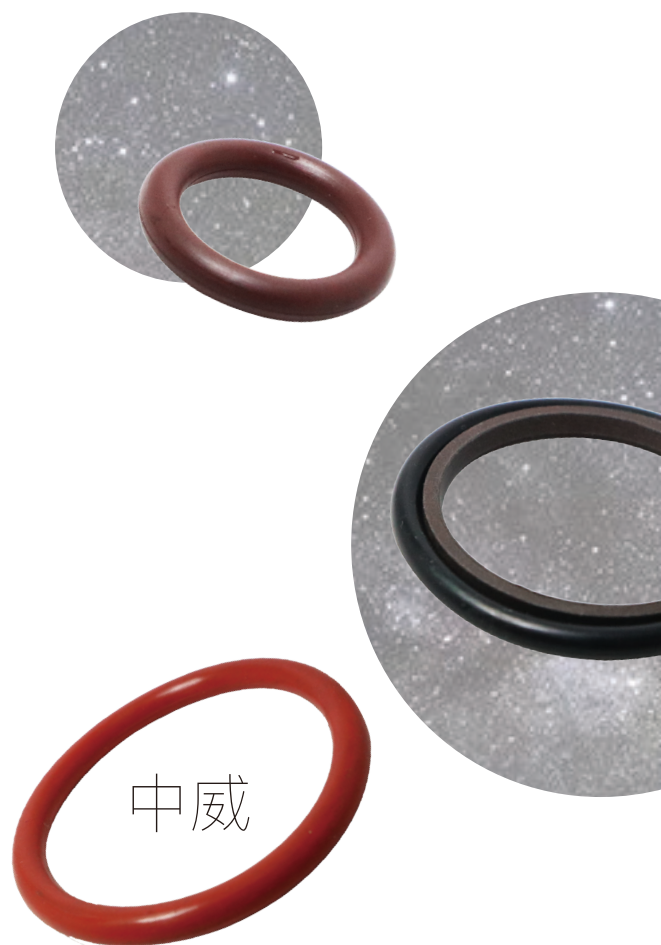

帶您一同漫遊
O 環小世界

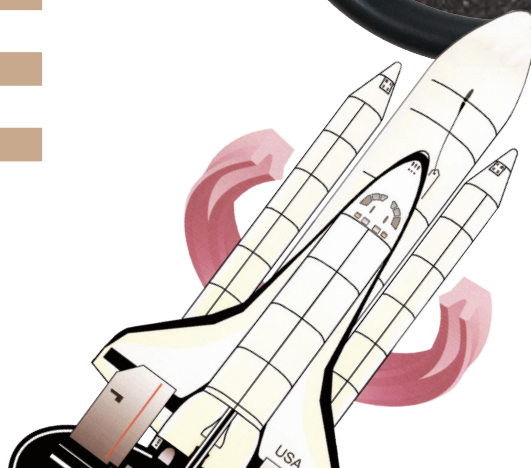



中威有限公司
CHUNG WEI CO.,LTD.

中威有限公司成立於西元 1984 年，我們位於大台南地區，專業從事於各式油封、導向元件、O 型環、重機油封、空壓油封、油壓油封、旋轉油封、注油器配件等密封元件的製造。

中威有限公司成立三十五年來本著“專業、服務、品質”的企業理念，受各工業界的好評肯定，我們有完善的經營團隊，面對不同客戶，我們提供完整的製造服務，對於特殊材質、尺寸、甚至複雜的產品設計，都能在短時間內完成。





常用橡膠特性與用途

Rubber Characteristics Are Used

優	可	尚可	差
◎	○	△	X

橡膠種類 (ASTM 簡稱)		橡膠 (NBR)	氟橡膠 (FPM)	矽橡膠 (SI)	乙烯、丙烯 橡膠 (EPM· EPDM)	天然橡膠 (NR)	
化學構造		丁二烯、丙烯 的共聚物	6氟丙烯氟乙 烯共聚物	Polysiloxane	乙烯、丙烯共 聚物(三元共 聚物)	聚異戊二烯	
主要特徵		具有良好的耐油 性、耐磨耗性、 耐老化性，不耐 極性溶劑	具有優越的耐熱 性及耐藥品性。	具有高度的耐熱 性及耐寒性	具有良好的耐老 化性、耐臭氧 性、對極性液體 的抵抗性 電的性質。	具有最向所謂橡 膠的彈性。耐磨 耗性等的機械性 質良 好。	
純橡膠的性質	比重	1.00 ~ 1.20	1.80 ~ 1.82	0.95 ~ 0.98	0.86 ~ 0.87	0.92	
	姆尼黏度 ML1+4(100℃)	30 ~ 100	65 ~ 180	液狀	50 ~ 150	90 ~ 150	
合成橡膠的 物理性質及 特性	可能 JIS 的硬度範圍	15 ~ 100	50 ~ 90	30 ~ 90	30 ~ 90	10 ~ 100	
	抗張強度 (kg/cm ²)	50 ~ 250	70 ~ 200	40 ~ 100	50 ~ 200	30 ~ 300	
	伸長 (%)	800 ~ 100	500 ~ 100	500 ~ 50	800 ~ 100	1000 ~ 100	
	反彈性	○	△	◎	○	◎	
	生裂	○	○	X~△	△	◎	
	耐磨耗性	◎	◎	X~△	○	◎	
	耐彎曲龜裂性	○	○	X~○	○	◎	
	耐熱性 (°C) (最高使用溫度)	130	300	280	150	120	
	耐寒性 (脆化溫度 °C)	-10 ~ -20	-10 ~ -50	-70 ~ -120	-40 ~ -60	-50 ~ -70	
	耐老化性	◎	◎	◎	◎	○	
	耐光性	○	◎	◎	◎	○	
	耐臭氧性	X	◎	◎	◎	X	
	耐焰性	~△	◎	X~○	X	X	
	耐氣體透過性	○	◎	△	○	○	
耐放射線性	△~○	△~○	△~◎	X	△~○		
化成橡膠的 耐油	耐溶劑性	汽油·輕油	◎	◎	X~△	X	X
		苯·甲苯	X~△	◎	X~△	△	X
		液脂	X	○	X~○	X	◎
		醇	◎	◎	◎	◎	X
		醚	X~△	X~△	X~△	○	△~○
		酮 (MEK)	X	X	○	◎	X~△
		乙酸·乙酯	X~△	X	△	◎	◎
化成橡膠的	耐酸耐鹼性	水	◎	◎	○	◎	X
		有機酸	X~△	X	○	X	X
		高濃度無機酸	△	◎	△	○	○
		低濃度無機酸	○	◎	○	◎	○
		高濃度鹼	○	X	◎	◎	○
		低濃度鹼	○	△	◎	◎	
主要用途		油封、軟墊、耐 油軟管、燃油 箱、液壓油、矽 油、矽潤滑脂水 等耐油產品	耐熱、耐油、耐 藥品性的火箭飛 彈軟墊、化工廠 的耐蝕軟墊、襯 片、 O環、隔膜、箱 內襯、軟管、 泵零件及半導體 工業之密封件。	軟墊、襯片、油 封、工業用滾 、防振動橡膠等耐 熱、耐寒用途電 絕緣用醫療、陶 器製造、家用電 器、電子業、食 品機械等	電線披覆、汽車 的阻風帶、窗框 橡膠、蒸氣軟 管、輸送帶。	汽車特別大型汽 車輪胎，產業用 索引車輪胎、 靴、軟管、 帶、空氣彈簧等 一般用品及工業 用品。	

O 環與工作壓力參考表

O-Ring Working Pressure

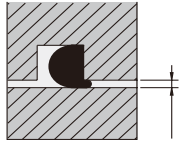

間隙公差

線徑 Cross section (mm)	間隙公差 Radial clearance (mm)	壓力 Pressure (kg/cm ²)	硬度	35	70	105	140	175	210	350
			SHORE A	Kg/CM2	Kg/CM2	Kg/CM2	Kg/CM2	Kg/CM2	Kg/CM2	Kg/CM2
1.78 m/m			70	0.15	0.1	0.05				
			80	0.2	0.15	0.1	0.05	0.03		
			90	0.25	0.2	0.13	0.1	0.08	0.05	0.03
2.62 m/m			70	0.18	0.13	0.08				
			80	0.25	0.18	0.13	0.08	0.04		
			90	0.3	0.25	0.18	0.13	0.1	0.08	0.04
3.53 m/m			70	0.2	0.15	0.1				
			80	0.3	0.2	0.15	0.1	0.05		
			90	0.4	0.3	0.2	0.15	0.13	0.1	0.05
5.33 m/m			70	0.25	0.18	0.13				
			80	0.35	0.25	0.18	0.13	0.06		
			90	0.45	0.35	0.25	0.18	0.15	0.13	0.06
6.99 m/m			70	0.3	0.2	0.15				
			80	0.4	0.3	0.2	0.15	0.07		
			90	0.5	0.4	0.3	0.2	0.18	0.15	0.07

O 環線徑公差

O-Ringn Tolerance

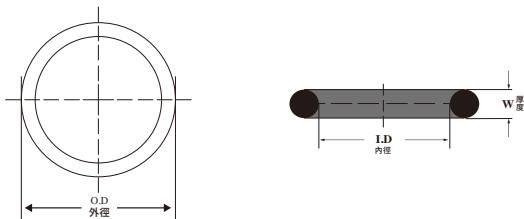

單位 unit : mm

線徑 W	公差 (+/-) tolerance
0-1.8	0.08
1.81-2.65	0.09
2.66-3.55	0.1
3.56-5.3	0.13
5.31-7	0.15
7.01-8.7	0.18
8.71-10.4	0.22

O 環尺寸公差參考表

O-Ring Tolerance

單位 unit : mm

內徑	公差 (+/-) tolerance	內徑	公差 (+/-) tolerance	內徑	公差 (+/-) tolerance	內徑	公差 (+/-) tolerance
1.8-2.5	0.13	54.51-56	0.51	150.01-155	1.24	412.01-425	2.99
2.51-4.5	0.14	56.01-58	0.52	155.01-160	1.27	425.01-437	3.07
4.51-6.3	0.15	58.01-60	0.54	160.01-165	1.31	437.01-450	3.15
6.31-8.5	0.16	60.01-61.5	0.55	165.01-170	1.34	450.01-462	3.22
8.51-10	0.17	61.51-63	0.56	170.01-175	1.38	462.01-475	3.3
10.01-11.2	0.18	63.01-65	0.58	175.01-180	1.41	475.01-487	3.37
11.21-14	0.19	65.01-67	0.59	180.01-185	1.44	487.01-500	3.45
14.01-16	0.2	67.01-69	0.61	185.01-190	1.48	500.01-515	3.54
16.01-18	0.21	69.01-71	0.63	190.01-195	1.51	515.01-530	3.63
18.01-20	0.22	71.01-73	0.64	195.01-200	1.55	530.01-545	3.72
20.01-21.2	0.23	73.01-75	0.66	200.01-206	1.59	545.01-560	3.81
21.21-23.6	0.24	75.01-77.5	0.67	206.01-212	1.63	560.01-580	3.93
23.61-25	0.25	77.51-80	0.69	212.01-218	1.67	580.01-600	4.05
25.01-26.5	0.26	80.01-82.5	0.71	218.01-224	1.71	600.01-615	4.13
26.51-28	0.28	82.51-85	0.73	224.01-230	1.75	615.01-630	4.22
28.01-30	0.29	85.01-87.5	0.75	230.01-236	1.79	630.01-650	4.34
30.01-31.5	0.31	87.51-90	0.77	236.01-243	1.83	650.01-670	4.46
31.51-33.5	0.32	90.01-92.5	0.79	243.01-250	1.88		
33.51-34.5	0.33	92.51-95	0.81	250.01-258	1.93		
34.51-35.5	0.34	95.01-97.5	0.83	258.01-265	1.98		
35.51-36.5	0.35	97.51-100	0.84	265.01-272	2.02		
36.51-37.5	0.36	100.01-103	0.87	272.01-280	2.08		
37.51-38.7	0.37	103.01-106	0.89	280.01-290	2.14		
38.71-40	0.38	106.01-109	0.91	290.01-300	2.21		
40.01-41.2	0.39	109.01-112	0.93	300.01-307	2.25		
41.21-42.5	0.4	112.01-115	0.95	307.01-315	2.3		
42.51-43.7	0.41	115.01-118	0.97	315.01-325	2.37		
43.71-45	0.42	118.01-122	1	325.01-335	2.43		
45.01-46.2	0.43	122.01-125	1.03	335.01-345	2.49		
46.21-47.5	0.44	125.01-128	1.05	345.01-355	2.56		
47.51-48.7	0.45	128.01-132	1.08	355.01-365	2.62		
48.71-50	0.46	132.01-136	1.1	365.01-375	2.68		
50.01-51.5	0.47	136.01-140	1.13	375.01-387	2.76		
51.51-53	0.48	140.01-145	1.17	387.01-400	2.84		
53.01-54.5	0.5	145.01-150	1.2	400.01-412	2.91		

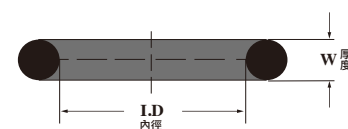
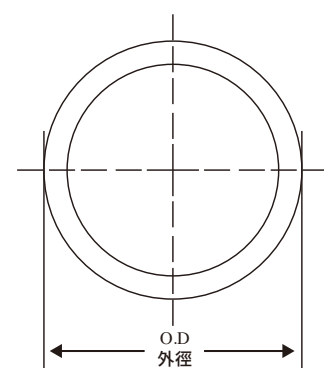

O 環與元件加工尺寸參考表

O-Ring Size List



圖 1



圖 2

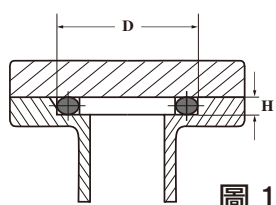

圖 3

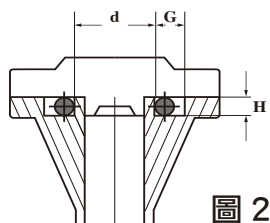

單位 unit : mm

靜態使用時 圖 1

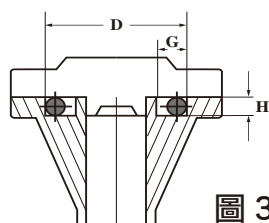
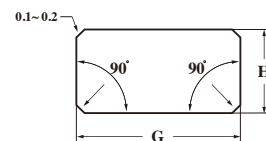
O環線徑 W	槽深 H	槽寬 G
1	0.8	1.3
1.5	1.1	1.9
1.6	1.2	2.1
1.78	1.3	2.3
1.9	1.4	2.4
2	1.5	2.6
2.4	1.8	3.1
2.5	1.9	3.2
2.62	2	3.4
2.7	2.1	3.5
3	2.3	3.9
3.5	2.7	4.5
3.53	2.7	4.5
3.6	2.8	4.7
4	3.15	5.2
4.5	3.6	5.8
5	4	6.5
5.33	4.3	6.9
5.5	4.5	7.1
5.7	4.65	7.4
6	4.95	7.8
6.5	5.4	8.4
6.99	5.85	9.1
7	5.85	9.1
7.5	6.3	9.7
8	6.75	10.4
8.4	7.15	10.9
8.5	7.25	11
9	7.7	11.7
9.5	8.2	12.3
10	8.65	13

動態使用 (氣體介質) 圖 2

O環線徑 W	槽深 H	槽寬 G
1	0.95	1.3
1.5	1.35	1.9
1.6	1.45	2
1.78	1.55	2.3
1.9	1.75	2.4
2	1.8	2.4
2.4	2.15	2.9
2.5	2.25	3
2.62	2.35	3.1
2.7	2.45	3.2
3	2.75	3.6
3.5	3.25	4.2
3.53	3.25	4.2
3.6	3.35	4.3
4	3.7	4.8
4.5	4.2	5.4
5	4.65	6
5.33	4.95	6.4
5.5	5.15	6.6
5.7	5.35	6.9
6	5.65	7.2
6.5	6.1	7.8
6.99	6.6	8.4
7	6.6	8.4
7.5	7.1	9
8	7.76	9.6
8.4	7.9	10.1
8.5	8	10.2
9	8.5	10.8
9.5	9	11.4
10	9.5	12

動態使用 (液態介質) 圖 3

O環線徑 W	槽深 H	槽寬 G
1	0.9	1.3
1.5	1.3	1.9
1.6	1.4	2
1.78	1.5	2.3
1.9	1.6	2.4
2	1.7	2.4
2.4	2.1	2.9
2.5	2.2	3
2.62	2.3	3.1
2.7	2.4	3.2
3	2.6	3.6
3.5	3.1	4.2
3.53	3.1	4.2
3.6	3.2	4.3
4	3.5	4.8
4.5	4	5.4
5	4.45	6
5.33	4.7	6.4
5.5	4.95	6.6
5.7	5.1	6.9
6	5.4	7.2
6.5	5.8	7.8
6.99	6.3	8.4
7	6.3	8.4
7.5	6.7	9
8	7.2	9.6
8.4	7.6	10.1
8.5	7.7	10.2
9	8.2	10.8
9.5	8.6	11.4
10	9.1	12

過度擠壓



■ 描述：

此密封件顯示出因封口過度擠壓，則呈現與溝槽一樣的平面形狀，也促使密封件表面出現裂痕。

■ 建議解決方案：

1. 密封元件的設計應考量使用耐熱性與化學反應的抵抗。
2. 勿過度的施力去強迫安裝，力道適中即可。

擠壓



■ 描述：

此密封件表面呈現出在低壓情況下內徑中呈現破爛的邊緣。

■ 建議解決方案：

1. 使品質良好或硬度較高的密封元件。
2. 合適的溝槽設計，密封間加工時間要足夠。
3. 慎選密封元件勿購買價格過於低廉之產品。

壓縮



■ 描述：

此密封件表面有如平坦橫斷面。

■ 建議解決方案：

1. 改用壓縮至較高程度的密封件。
2. 增加密封件的硬度及確保密封件的品質。

擦傷



■ 描述：

此密封件已被壓迫平行，且平面受到灰塵的擦傷。

■ 建議解決方案：

1. 在密封件上塗抹適當的潤滑油已減少摩擦。
2. 減少在不良的溝槽上裝設密封件。

安裝損失



■ 描述：

此密封件表面呈現割破的刀口。

■ 建議解決方案：

1. 合適的溝槽設計及避免鋒利的零件。
2. 使用品質良好或硬度較高的密封件。

離子體衝擊



■ 描述：

此密封件呈現變色，表面上還有被侵蝕的損傷與粉末殘餘。

■ 建議解決方案：

1. 使用能抵抗電離子或可抵抗某些化學性質的密封件。
2. 檢查溝槽的設計，以抵達遭受電離子的衝擊。

氣體外洩



■ 描述：

此密封件顯示出不能完全密封住封口。

■ 建議解決方案：

1. 避免使用塑化性高的密封件及慎選密封件勿購買價格過於低廉之產品。
2. 確保密封件的大小合適溝槽中，以免氣體外洩及正確計算溫度與壓力的比例。
3. 選擇正確材質

急遽減壓



■ 描述：

此密封件表面呈現水泡、凹凸不平、坑洞等。

■ 建議解決方案：

1. 使用品質良好或硬度較高的密封件。
2. 緩慢的上升或下降氣壓。

污染

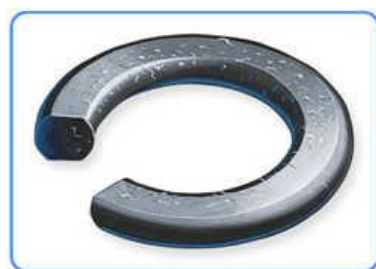

■ 描述：

密封件在表面或毛邊線部分出現污染物質。

■ 建議解決方案：

1. 詳細於包裝上註明污染物的級別含製造及包裝。

化學侵蝕



■ 描述：

此密封件表面呈現水泡、裂痕、空洞、變色等反應。

■ 建議解決方案：

1. 使用可抗某些化學物質或耐熱性高的產品。

熱氣侵蝕沾黏



■ 描述：

此密封件表面高溫下而呈現爆裂會與工件沾黏。

■ 建議解決方案：

1. 使用具有熱安定性的密封件。
2. 選擇霧面處理的密封件。

螺旋紋



■ 描述：

此密封件表面有被切傷與螺旋痕跡。

■ 建議解決方案：

1. 正確的安裝，潤滑與設計密封件。
2. 使用品質良好及硬度較高的密封件。

O 環 P 規格

P-Type O-Ring Size List

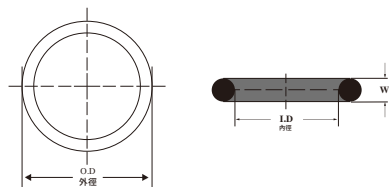

單位 unit : mm

材質	橡膠	橡膠 (高壓)	氟橡膠 (耐熱)	矽橡膠
	NBR70	NBR90	VT	SE

O 環 P 規格	內徑 I.D.	外徑 O.D.	厚度 w
P-2	1.8	5.6	1.9
P-3	2.8	6.6	1.9
P-4	3.8	7.6	1.9
P-5	4.8	8.6	1.9
P-6	5.8	9.6	1.9
P-7	6.8	10.6	1.9
P-8	7.8	11.6	1.9
P-9	8.8	12.6	1.9
P-10	9.8	13.6	1.9
P-10A	9.8	14.6	2.4
P-11	10.8	15.6	2.4
P-11.2	11	15.8	2.4
P-12	11.8	16.6	2.4
P-12.5	12.3	17.1	2.4
P-13	12.8	17.6	2.4
P-14	13.8	18.6	2.4
P-15	14.8	19.6	2.4
P-16	15.8	20.6	2.4
P-17	16.8	21.6	2.4
P-18	17.8	22.6	2.4
P-19	18.8	23.6	2.4
P-20	19.8	24.6	2.4
P-21	20.8	25.6	2.4
P-22	21.8	26.6	2.4
P-22A	21.7	28.7	3.5
P-22.4	22.1	29.1	3.5
P-24	23.7	30.7	3.5
P-25	24.7	31.7	3.5
P-25.5	25.2	32.2	3.5
P-26	25.7	32.7	3.5
P-28	27.7	34.7	3.5
P-29	28.7	35.7	3.5
P-29.5	29.2	36.2	3.5
P-30	29.7	36.7	3.5
P-31	30.7	37.7	3.5
P-31.5	31.2	38.2	3.5
P-32	31.7	38.7	3.5
P-34	33.7	40.7	3.5

O 環 P 規格	內徑 I.D.	外徑 O.D.	厚度 w
P-35	34.7	41.7	3.5
P-35.5	35.2	42.2	3.5
P-36	35.7	42.7	3.5
P-38	37.7	44.7	3.5
P-39	38.7	45.7	3.5
P-40	39.7	46.7	3.5
P-41	40.7	47.7	3.5
P-42	41.7	48.7	3.5
P-44	43.7	50.7	3.5
P-45	44.7	51.7	3.5
P-46	45.7	52.7	3.5
P-47A	46.6	58	5.7
P-48	47.7	54.7	3.5
P-48A	47.6	59	5.7
P-49	48.7	55.7	3.5
P-50	49.7	56.7	3.5
P-50A	49.6	61	5.7
P-52	51.6	63	5.7
P-53	52.6	64	5.7
P-55	54.6	66	5.7
P-56	55.6	67	5.7
P-58	57.6	69	5.7
P-60	59.6	71	5.7
P-62	61.6	73	5.7
P-63	62.6	74	5.7
P-65	64.6	76	5.7
P-67	66.6	78	5.7
P-70	69.6	81	5.7
P-71	70.6	82	5.7
P-75	74.6	86	5.7
P-80	79.6	91	5.7
P-85	84.6	96	5.7
P-90	89.6	101	5.7
P-95	94.6	106	5.7
P-100	99.6	111	5.7
P-102	101.6	113	5.7
P-105	104.6	116	5.7
P-110	109.6	121	5.7

專業製造：橡膠 O 環、U 型 O 環、V 型 O 環、迫緊、膜片、鐵氟龍、橡膠訂作規格外陸續開模中，請歡迎來電洽詢。

此規格材質 NBR90、VT、SE 若有需要需詢問。

O 環 P 規格

P-Type O-Ring Size List

材質	橡膠	橡膠 (高壓)	氟橡膠 (耐熱)	矽橡膠
	NBR70	NBR90	VT	SE

單位 unit : mm

O 環 P 規格	內徑 I.D.	外徑 O.D.	厚度 w
P-112	111.6	123	5.7
P-115	114.6	126	5.7
P-120	119.6	131	5.7
P-125	124.6	136	5.7
P-130	129.6	141	5.7
P-132	131.6	143	5.7
P-135	134.6	146	5.7
P-140	139.6	151	5.7
P-145	144.6	156	5.7
P-150	149.6	161	5.7
P-150A	149.5	166.3	8.4
P-155	154.5	171.3	8.4
P-160	159.5	176.3	8.4
P-165	164.5	181.3	8.4
P-170	169.5	186.3	8.4
P-175	174.5	191.3	8.4
P-180	179.5	196.3	8.4
P-185	184.5	201.3	8.4
P-190	189.5	206.3	8.4
P-195	194.5	211.3	8.4
P-200	199.5	216.3	8.4
P-205	204.5	221.3	8.4
P-209	208.5	225.3	8.4
P-210	209.5	226.3	8.4
P-215	214.5	231.3	8.4
P-220	219.5	236.3	8.4
P-225	224.5	241.3	8.4
P-230	229.5	246.3	8.4
P-235	234.5	251.3	8.4
P-240	239.5	256.3	8.4
P-245	244.5	261.3	8.4
P-250	249.5	266.3	8.4
P-255	254.5	271.3	8.4
P-260	259.5	276.3	8.4
P-265	264.5	281.3	8.4
P-270	269.5	286.3	8.4
P-275	274.5	291.3	8.4
P-280	279.5	296.3	8.4

O 環 P 規格	內徑 I.D.	外徑 O.D.	厚度 w
P-285	284.5	301.3	8.4
P-290	289.5	306.3	8.4
P-295	294.5	311.3	8.4
P-300	299.5	316.3	8.4
P-305	304.5	321.3	8.4
P-310	309.5	326.3	8.4
P-315	314.5	331.3	8.4
P-320	319.5	336.3	8.4
P-325	324.5	341.3	8.4
P-330	329.5	346.3	8.4
P-335	334.5	351.3	8.4
P-340	339.5	356.3	8.4
P-345	344.5	361.3	8.4
P-350	349.9	366.3	8.4
P-355	354.5	371.3	8.4
P-360	359.5	376.3	8.4
P-365	364.5	381.3	8.4
P-370	369.5	386.3	8.4
P-375	374.5	391.3	8.4
P-380	379.5	396.3	8.4
P-385	384.5	401.3	8.4
P-390	389.5	406.3	8.4
P-395	394.5	411.3	8.4
P-400	399.5	416.3	8.4

專業製造：橡膠 O 環、U 型 V 迫緊、膜片、鐵氟龍、橡膠訂作規格外陸續開模中，請歡迎來電洽詢。

此規格材質 NBR90、VT、SE 若有需要需詢問。

O 環 G 規格

P-Type O-Ring Size List



中威密封元件

材質	橡膠	橡膠 (高壓)	氟橡膠 (耐熱)	矽橡膠
	NBR70	NBR90	VT	SE

單位 unit : mm

O 環 G 規格	內徑 I.D.	外徑 O.D.	厚度 w
G-25	24.4	30.6	3.1
G-30	29.4	35.6	3.1
G-35	34.4	40.6	3.1
G-40	39.4	45.6	3.1
G-45	44.4	50.6	3.1
G-50	49.4	55.6	3.1
G-55	54.4	60.6	3.1
G-58	57.4	63.6	3.1
G-60	59.4	65.6	3.1
G-65	64.4	70.6	3.1
G-70	69.4	75.6	3.1
G-75	74.4	80.6	3.1
G-80	79.4	85.6	3.1
G-85	84.4	90.6	3.1
G-90	89.4	95.6	3.1
G-95	94.4	100.6	3.1
G-100	99.4	105.6	3.1
G-105	104.4	110.6	3.1
G-110	109.4	115.6	3.1
G-115	114.4	120.6	3.1
G-120	119.4	125.6	3.1
G-125	124.4	130.6	3.1
G-130	129.4	135.6	3.1
G-135	134.4	140.6	3.1
G-140	139.4	145.6	3.1
G-145	144.4	150.6	3.1
G-150	149.3	160.7	5.7
G-155	154.3	165.7	5.7
G-160	159.3	170.7	5.7
G-165	164.3	175.7	5.7
G-170	169.3	180.7	5.7
G-175	174.3	185.7	5.7
G-180	179.3	190.7	5.7
G-185	184.3	195.7	5.7
G-190	189.3	200.7	5.7
G-195	194.3	205.7	5.7

O 環 G 規格	內徑 I.D.	外徑 O.D.	厚度 w
G-200	199.3	210.7	5.7
G-205	204.3	215.7	5.7
G-210	209.3	220.7	5.7
G-215	214.3	225.7	5.7
G-220	219.3	230.7	5.7
G-225	224.3	235.7	5.7
G-230	229.3	240.7	5.7
G-235	234.3	245.7	5.7
G-240	239.3	250.7	5.7
G-245	244.3	255.7	5.7
G-250	249.3	260.7	5.7
G-255	254.3	265.7	5.7
G-260	259.3	270.7	5.7
G-265	264.3	275.7	5.7
G-270	269.3	280.7	5.7
G-275	274.3	285.7	5.7
G-280	279.3	290.7	5.7
G-285	284.3	295.7	5.7
G-290	289.3	300.7	5.7
G-295	294.3	305.7	5.7
G-300	299.3	310.7	5.7

專業製造：橡膠 O 環、U-V 迫緊、膜片、鐵氟龍、橡膠訂作規格外陸續開模中，請歡迎來電洽詢。

此規格材質 NBR90、VT、SE 若有需要需詢問。

O 環 G 特殊規格

G-Special Type O-Ring Size List

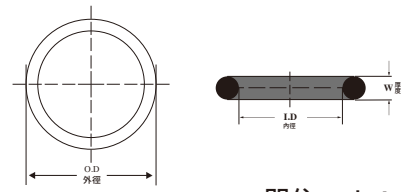

單位 unit : mm

材質	橡膠	橡膠(高壓)	氟橡膠(耐熱)	矽橡膠
	NBR70	NBR90	VT	SE

O 環 G 規格	內徑 I.D.	外徑 O.D.	厚度 w
G-305	304.3	315.7	5.7
G-310	309.3	320.7	5.7
G-315	314.3	325.7	5.7
G-320	319.3	330.7	5.7
G-325	324.3	335.7	5.7
G-330	329.3	340.7	5.7
G-335	334.3	345.7	5.7
G-340	339.3	350.7	5.7
G-345	344.3	355.7	5.7
G-350	349.3	360.7	5.7
G-355	354.3	365.7	5.7
G-360	359.3	370.7	5.7
G-365	364.3	375.7	5.7
G-370	369.3	380.7	5.7
G-375	374.3	385.7	5.7
G-380	379.3	390.7	5.7
G-385	384.3	395.7	5.7
G-390	389.3	400.7	5.7
G-395	394.3	405.7	5.7
G-400	399.3	410.7	5.7
G-405	404.3	415.7	5.7
G-410	409.3	420.7	5.7
G-415	414.3	425.7	5.7
G-420	419.3	430.7	5.7
G-425	424.3	435.7	5.7
G-430	429.3	440.7	5.7
G-435	434.3	445.7	5.7
G-440	439.3	450.7	5.7
G-445	444.3	455.7	5.7
G-450	449.3	460.7	5.7
G-455	454.3	465.7	5.7
G-460	459.3	470.7	5.7
G-465	464.3	475.7	5.7
G-470	469.3	480.7	5.7
G-475	474.3	485.7	5.7
G-480	479.3	490.7	5.7
G-485	484.3	495.7	5.7
G-490	489.3	500.7	5.7

O 環 G 規格	內徑 I.D.	外徑 O.D.	厚度 w
G-495	494.3	505.7	5.7
G-500	499.3	510.7	5.7
G-505	504.3	515.7	5.7
G-510	509.3	520.7	5.7
G-515	514.3	525.7	5.7
G-520	519.3	530.7	5.7
G-525	524.3	535.7	5.7
G-530	529.3	540.7	5.7
G-535	534.3	545.7	5.7
G-540	539.3	550.7	5.7
G-545	544.3	555.7	5.7
G-550	549.3	560.7	5.7
G-555	554.3	565.7	5.7
G-560	559.3	570.7	5.7
G-565	564.3	575.7	5.7
G-570	569.3	580.7	5.7
G-575	574.3	585.7	5.7
G-580	579.3	590.7	5.7
G-585	584.3	595.7	5.7
G-590	589.3	600.7	5.7
G-595	594.3	605.7	5.7
G-600	599.3	610.7	5.7

專業製造：橡膠 O 環、U-V 迫緊、膜片、鐵氟龍、橡膠訂作規格外陸續開模中，請歡迎來電洽詢。

此規格材質 NBR90、VT、SE 若有需要需詢問。

O 環 AS-568 規格

AS-568-Type O-Ring Size List

材質	橡膠	橡膠(高壓)	氟橡膠(耐熱)	矽橡膠
	NBR70	NBR90	VT	SE

單位 unit : mm

O 環 AS-568 規格	內徑 I.D.	外徑 O.D.	厚度 w
AS-001	0.74	2.78	1.02
AS-002	1.07	3.61	1.27
AS-003	1.42	4.48	1.53
AS-004	1.78	5.34	1.78
AS-005	2.57	6.13	1.78
AS-006	2.9	6.46	1.78
AS-007	3.69	7.25	1.78
AS-008	4.47	8.03	1.78
AS-009	5.29	8.85	1.78
AS-010	6.07	9.63	1.78
AS-011	7.65	11.21	1.78
AS-012	9.25	12.81	1.78
AS-013	10.82	14.38	1.78
AS-014	12.42	15.98	1.78
AS-015	14	17.56	1.78
AS-016	15.6	19.16	1.78
AS-017	17.17	20.73	1.78
AS-018	18.77	22.33	1.78
AS-019	20.35	23.91	1.78
AS-020	21.95	25.51	1.78
AS-021	23.52	27.08	1.78
AS-022	25.12	28.68	1.78
AS-023	26.7	30.26	1.78
AS-024	28.3	31.86	1.78
AS-025	29.87	33.43	1.78
AS-026	31.47	35.03	1.78
AS-027	33.05	36.61	1.78
AS-028	34.65	38.21	1.78
AS-029	37.82	41.38	1.78
AS-030	41	44.56	1.78
AS-031	44.17	47.73	1.78
AS-032	47.35	50.91	1.78
AS-033	50.52	54.08	1.78
AS-034	53.7	57.26	1.78
AS-035	56.87	60.43	1.78
AS-036	60.04	63.6	1.78
AS-037	63.22	66.78	1.78
AS-038	66.4	69.96	1.78

O 環 AS-568 規格	內徑 I.D.	外徑 O.D.	厚度 w
AS-039	69.57	73.13	1.78
AS-040	72.75	76.31	1.78
AS-041	75.92	79.48	1.78
AS-042	82.27	85.83	1.78
AS-043	88.62	92.18	1.78
AS-044	94.97	98.53	1.78
AS-045	101.32	104.88	1.78
AS-046	107.62	111.18	1.78
AS-047	114.02	117.58	1.78
AS-048	120.37	123.93	1.78
AS-049	126.72	130.28	1.78
AS-050	133.07	136.63	1.78
AS-102	1.24	6.48	2.62
AS-103	2.05	7.29	2.62
AS-104	2.84	8.08	2.62
AS-105	3.63	8.87	2.62
AS-106	4.42	9.66	2.62
AS-107	5.23	10.47	2.62
AS-108	6.02	11.26	2.62
AS-109	7.6	12.84	2.62
AS-110	9.19	14.43	2.62
AS-111	10.77	16.01	2.62
AS-112	12.37	17.61	2.62
AS-113	13.95	19.19	2.62
AS-114	15.54	20.78	2.62
AS-115	17.12	22.36	2.62
AS-116	18.72	23.96	2.62
AS-117	20.29	25.53	2.62
AS-118	21.9	27.14	2.62
AS-119	23.47	28.71	2.62
AS-120	25.07	30.31	2.62
AS-121	26.65	31.89	2.62
AS-122	28.25	33.49	2.62
AS-123	29.82	35.06	2.62
AS-124	31.42	36.66	2.62
AS-125	32.99	38.23	2.62
AS-126	34.6	39.84	2.62
AS-127	36.17	41.41	2.62

專業製造：橡膠 O 環、U-V 迫緊、膜片、鐵氟龍、橡膠訂作規格外陸續開模中，請歡迎來電洽詢。

此規格材質 NBR90、VT、SE 若有需要需詢問。

O 環 AS-568 規格

AS-568-Type O-Ring Size List

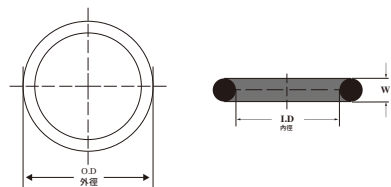

單位 unit : mm

材質	橡膠	橡膠 (高壓)	氟橡膠 (耐熱)	矽橡膠
	NBR70	NBR90	VT	SE

O 環 AS-568 規格	內徑 I.D.	外徑 O.D.	厚度 w
AS-128	37.77	43.01	2.62
AS-129	39.35	44.59	2.62
AS-130	40.95	46.19	2.62
AS-131	42.52	47.76	2.62
AS-132	44.12	49.36	2.62
AS-133	45.7	50.94	2.62
AS-134	47.3	52.54	2.62
AS-135	48.9	54.14	2.62
AS-136	50.47	55.71	2.62
AS-137	52.07	57.31	2.62
AS-138	53.65	58.89	2.62
AS-139	55.25	60.49	2.62
AS-140	56.82	62.06	2.62
AS-141	58.42	63.66	2.62
AS-142	60	65.24	2.62
AS-143	61.6	66.84	2.62
AS-144	63.17	68.41	2.62
AS-145	64.77	70.01	2.62
AS-146	66.35	71.59	2.62
AS-147	67.95	73.19	2.62
AS-148	69.52	74.76	2.62
AS-149	71.12	76.36	2.62
AS-150	72.7	77.94	2.62
AS-151	75.87	81.11	2.62
AS-152	82.22	87.46	2.62
AS-153	88.57	93.81	2.62
AS-154	94.92	100.16	2.62
AS-155	101.27	106.51	2.62
AS-156	107.62	112.86	2.62
AS-157	113.97	119.21	2.62
AS-158	120.32	125.56	2.62
AS-159	126.67	131.91	2.62
AS-160	133.02	138.26	2.62
AS-161	139.37	144.61	2.62
AS-162	145.72	150.96	2.62
AS-163	152.07	157.31	2.62
AS-164	158.42	163.66	2.62
AS-165	164.77	170.01	2.62

O 環 AS-568 規格	內徑 I.D.	外徑 O.D.	厚度 w
AS-166	171.12	176.36	2.62
AS-167	177.47	182.71	2.62
AS-168	183.82	189.06	2.62
AS-169	190.17	195.41	2.62
AS-170	196.52	201.76	2.62
AS-171	202.87	208.11	2.62
AS-172	209.22	214.46	2.62
AS-173	215.57	220.81	2.62
AS-174	221.92	227.16	2.62
AS-175	228.27	233.51	2.62
AS-176	234.62	239.86	2.62
AS-177	240.97	246.21	2.62
AS-178	247.32	252.56	2.62
AS-201	4.34	11.4	3.53
AS-202	5.94	13	3.53
AS-203	7.52	14.58	3.53
AS-204	9.12	16.18	3.53
AS-205	10.69	17.75	3.53
AS-206	12.29	19.35	3.53
AS-207	13.87	20.93	3.53
AS-208	15.47	22.53	3.53
AS-209	17.04	24.1	3.53
AS-210	18.64	25.7	3.53
AS-211	20.22	27.28	3.53
AS-212	21.82	28.88	3.53
AS-213	23.4	30.46	3.53
AS-214	25	32.06	3.53
AS-215	26.57	33.63	3.53
AS-216	28.17	35.23	3.53
AS-217	29.75	36.81	3.53
AS-218	31.34	38.4	3.53
AS-219	32.92	39.98	3.53
AS-220	34.52	41.58	3.53
AS-221	36.1	43.16	3.53
AS-222	37.7	44.76	3.53
AS-223	40.87	47.93	3.53
AS-224	44.05	51.11	3.53
AS-225	47.22	54.28	3.53

專業製造：橡膠 O 環、U-V 迫緊、膜片、鐵氟龍、橡膠訂作規格外陸續開模中，請歡迎來電洽詢。

此規格材質 NBR90、VT、SE 若有需要需詢問。

O 環 AS-568 規格

AS-568-Type O-Ring Size List

材質	橡膠	橡膠(高壓)	氟橡膠(耐熱)	矽橡膠
	NBR70	NBR90	VT	SE

單位 unit : mm

O 環 AS-568 規格	內徑 I.D.	外徑 O.D.	厚度 w
AS-226	50.4	57.46	3.53
AS-227	53.57	60.63	3.53
AS-228	56.75	63.81	3.53
AS-229	59.92	66.98	3.53
AS-230	63.1	70.16	3.53
AS-231	66.27	73.33	3.53
AS-232	69.44	76.5	3.53
AS-233	72.62	79.68	3.53
AS-234	75.79	82.85	3.53
AS-235	78.97	86.03	3.53
AS-236	82.14	89.2	3.53
AS-237	85.32	92.38	3.53
AS-238	88.49	95.55	3.53
AS-239	91.67	98.73	3.53
AS-240	94.84	101.9	3.53
AS-241	98.02	105.08	3.53
AS-242	101.19	108.25	3.53
AS-243	104.37	111.43	3.53
AS-244	107.54	114.6	3.53
AS-245	110.72	117.78	3.53
AS-246	113.89	120.95	3.53
AS-247	117.07	124.13	3.53
AS-248	120.24	127.3	3.53
AS-249	123.42	130.48	3.53
AS-250	126.59	133.65	3.53
AS-251	129.77	136.83	3.53
AS-252	132.94	140	3.53
AS-253	136.12	143.18	3.53
AS-254	139.3	146.36	3.53
AS-255	142.47	149.53	3.53
AS-256	145.65	152.71	3.53
AS-257	148.82	155.88	3.53
AS-258	152	159.06	3.53
AS-259	158.35	165.41	3.53
AS-260	164.7	171.76	3.53
AS-261	171.05	178.11	3.53
AS-262	177.4	184.46	3.53
AS-263	183.75	190.81	3.53

O 環 AS-568 規格	內徑 I.D.	外徑 O.D.	厚度 w
AS-264	190.1	197.16	3.53
AS-265	196.45	203.51	3.53
AS-266	202.8	209.86	3.53
AS-267	209.15	216.21	3.53
AS-268	215.5	222.56	3.53
AS-269	221.85	228.91	3.53
AS-270	228.2	235.26	3.53
AS-271	234.55	241.61	3.53
AS-272	240.9	247.96	3.53
AS-273	247.25	254.31	3.53
AS-274	253.6	260.66	3.53
AS-275	266.3	273.36	3.53
AS-276	279	286.06	3.53
AS-277	291.7	298.76	3.53
AS-278	304.4	311.46	3.53
AS-279	329.8	336.86	3.53
AS-280	355.2	362.26	3.53
AS-281	380.6	387.66	3.53
AS-282	405.26	412.32	3.53
AS-283	430.66	437.72	3.53
AS-284	456.06	463.12	3.53
AS-309	10.46	21.12	5.33
AS-310	12.07	22.73	5.33
AS-311	13.64	24.3	5.33
AS-312	15.24	25.9	5.33
AS-313	16.81	27.47	5.33
AS-314	18.42	29.08	5.33
AS-315	19.99	30.65	5.33
AS-316	21.59	32.25	5.33
AS-317	23.16	33.82	5.33
AS-318	24.77	35.43	5.33
AS-319	26.34	37	5.33
AS-320	27.94	38.6	5.33
AS-321	29.51	40.17	5.33
AS-322	31.12	41.78	5.33
AS-323	32.69	43.35	5.33
AS-324	34.29	44.95	5.33
AS-325	37.47	48.13	5.33

專業製造：橡膠 O 環、U-V 迫緊、膜片、鐵氟龍、橡膠訂作規格外陸續開模中，請歡迎來電洽詢。

O 環 AS-568 規格

AS-568-Type O-Ring Size List

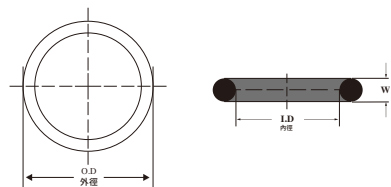

單位 unit : mm

材質	橡膠	橡膠 (高壓)	氟橡膠 (耐熱)	矽橡膠
	NBR70	NBR90	VT	SE

O 環 AS-568 規格	內徑 I.D.	外徑 O.D.	厚度 w
AS-326	40.65	51.31	5.33
AS-327	43.82	54.48	5.33
AS-328	46.99	57.65	5.33
AS-329	50.16	60.82	5.33
AS-330	53.34	64	5.33
AS-331	56.52	67.18	5.33
AS-332	59.69	70.35	5.33
AS-333	62.87	73.53	5.33
AS-334	66.04	76.7	5.33
AS-335	69.22	79.88	5.33
AS-336	72.39	83.05	5.33
AS-337	75.57	86.23	5.33
AS-338	78.74	89.4	5.33
AS-339	81.92	92.58	5.33
AS-340	85.09	95.75	5.33
AS-341	88.27	98.93	5.33
AS-342	91.44	102.1	5.33
AS-343	94.62	105.28	5.33
AS-344	97.79	108.45	5.33
AS-345	100.96	111.62	5.33
AS-346	104.14	114.8	5.33
AS-347	107.32	117.98	5.33
AS-348	110.49	121.15	5.33
AS-349	113.67	124.33	5.33
AS-350	116.84	127.5	5.33
AS-351	120.02	130.68	5.33
AS-352	123.19	133.85	5.33
AS-353	126.37	137.03	5.33
AS-354	129.54	140.2	5.33
AS-355	132.72	143.38	5.33
AS-356	135.89	146.55	5.33
AS-357	139.07	149.73	5.33
AS-358	142.24	152.9	5.33
AS-359	145.42	156.08	5.33
AS-360	148.59	159.25	5.33
AS-361	151.77	162.43	5.33
AS-362	158.12	168.78	5.33
AS-363	164.47	175.13	5.33

O 環 AS-568 規格	內徑 I.D.	外徑 O.D.	厚度 w
AS-364	170.82	181.48	5.33
AS-365	177.17	187.83	5.33
AS-366	183.52	194.18	5.33
AS-367	189.87	200.53	5.33
AS-368	196.22	206.88	5.33
AS-369	202.57	213.23	5.33
AS-370	208.92	219.58	5.33
AS-371	215.27	225.93	5.33
AS-372	221.62	232.28	5.33
AS-373	227.97	238.63	5.33
AS-374	234.32	244.98	5.33
AS-375	240.67	251.33	5.33
AS-376	247.02	257.68	5.33
AS-377	253.37	264.03	5.33
AS-378	266.07	276.73	5.33
AS-379	278.77	289.43	5.33
AS-380	291.47	302.13	5.33
AS-381	304.17	314.83	5.33
AS-382	329.55	340.21	5.33
AS-383	354.97	365.63	5.33
AS-384	380.37	391.03	5.33
AS-385	405.26	415.92	5.33
AS-386	430.65	441.31	5.33
AS-387	456.06	466.72	5.33
AS-388	481.46	492.12	5.33
AS-389	506.86	517.52	5.33
AS-390	532.26	542.92	5.33
AS-391	557.66	568.32	5.33
AS-392	582.65	593.31	5.33
AS-393	608.1	618.76	5.33
AS-394	633.5	644.16	5.33
AS-395	658.85	669.51	5.33
AS-401	58	72	7
AS-402	64	78	7
AS-403	68	82	7
AS-404	73	87	7
AS-405	79	93	7
AS-406	83	97	7

專業製造：橡膠 O 環、U 形 V 形、迫緊、膜片、鐵氟龍、橡膠訂作規格外陸續開模中，請歡迎來電洽詢。

此規格材質 NBR90、VT、SE 若有需要需詢問。

O 環 AS-568 規格

AS-568-Type O-Ring Size List

材質	橡膠	橡膠(高壓)	氟橡膠(耐熱)	矽橡膠
	NBR70	NBR90	VT	SE

單位 unit : mm

O 環 AS-568 規格	內徑 I.D.	外徑 O.D.	厚度 w
AS-407	89	103	7
AS-408	94	108	7
AS-409	99	113	7
AS-410	101	115	7
AS-411	106	120	7
AS-425	113.67	127.65	6.99
AS-426	116.84	130.82	6.99
AS-427	120.02	134	6.99
AS-428	123.19	137.17	6.99
AS-429	126.37	140.35	6.99
AS-430	129.54	143.52	6.99
AS-431	132.72	146.7	6.99
AS-432	135.89	149.87	6.99
AS-433	139.07	153.05	6.99
AS-434	142.24	156.22	6.99
AS-435	145.42	159.4	6.99
AS-436	148.59	162.57	6.99
AS-437	151.77	165.75	6.99
AS-438	158.12	172.1	6.99
AS-439	164.47	178.45	6.99
AS-440	170.82	184.8	6.99
AS-441	177.17	191.15	6.99
AS-442	183.52	197.5	6.99
AS-443	189.87	203.85	6.99
AS-444	196.22	210.2	6.99
AS-445	202.57	216.55	6.99
AS-446	215.27	229.25	6.99
AS-447	227.97	241.95	6.99
AS-448	240.67	254.65	6.99
AS-449	253.37	267.35	6.99
AS-450	266.07	280.05	6.99
AS-451	278.77	292.75	6.99
AS-452	291.47	305.45	6.99
AS-453	304.17	318.15	6.99
AS-454	316.87	330.85	6.99
AS-455	329.57	343.55	6.99
AS-456	342.27	356.25	6.99
AS-457	354.97	368.95	6.99

O 環 AS-568 規格	內徑 I.D.	外徑 O.D.	厚度 w
AS-458	367.67	381.65	6.99
AS-459	380.37	394.35	6.99
AS-460	393.07	407.05	6.99
AS-461	405.26	419.24	6.99
AS-462	417.96	431.94	6.99
AS-463	430.66	444.64	6.99
AS-464	443.36	457.34	6.99
AS-465	456.06	470.04	6.99
AS-466	468.76	482.74	6.99
AS-467	481.46	495.44	6.99
AS-468	494.16	508.14	6.99
AS-469	506.86	520.84	6.99
AS-470	532.26	546.24	6.99
AS-471	557.66	571.64	6.99
AS-472	582.65	596.63	6.99
AS-473	608.1	622.08	6.99
AS-474	633.5	647.48	6.99
AS-475	658.85	672.83	6.99
AS-901	4.7	7.54	1.42
AS-902	6.07	9.33	1.63
AS-903	7.65	10.91	1.63
AS-904	8.92	12.58	1.83
AS-905	10.52	14.18	1.83
AS-906	11.89	15.85	1.98
AS-907	13.46	17.62	2.08
AS-908	16.36	20.78	2.21
AS-909	17.94	22.86	2.46
AS-910	19.18	24.1	2.46
AS-911	21.92	27.82	2.95
AS-912	23.47	29.37	2.95
AS-913	25.04	30.94	2.95
AS-914	26.6	32.5	2.95
AS-916	29.75	35.65	2.95
AS-918	34.42	40.32	2.95
AS-920	37.46	43.46	3
AS-924	43.68	49.68	3
AS-928	53.09	59.09	3
AS-932	59.36	65.36	3

專業製造：橡膠 O 環、U-V 迫緊、膜片、鐵氟龍、橡膠訂作規格外陸續開模中，請歡迎來電洽詢。

O 環 S 規格

S-Type O-Ring Size List

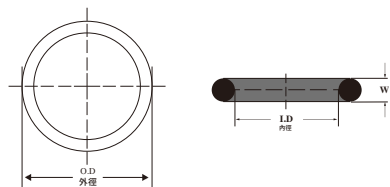

單位 unit : mm

材質	橡膠	橡膠 (高壓)	氟橡膠 (耐熱)	矽橡膠
	NBR70	NBR90	VT	SE

O 環 S 規格	內徑 I.D.	外徑 O.D.	厚度 w
S-002	1.5	4.5	1.5
S-003	2.5	5.5	1.5
S-004	3.5	6.5	1.5
S-005	4.5	7.5	1.5
S-006	5.5	8.5	1.5
S-007	6.5	9.5	1.5
S-008	7.5	10.5	1.5
S-009	8.5	11.5	1.5
S-010	9.5	12.5	1.5
S-11.2	10.7	13.7	1.5
S-012	11.5	14.5	1.5
S-12.5	12	15	1.5
S-014	13.5	16.5	1.5
S-015	14.5	17.5	1.5
S-016	15.5	18.5	1.5
S-018	17.5	20.5	1.5
S-020	19.5	22.5	1.5
S-022	21.5	24.5	1.5
S-22.4	21.9	25.9	2
S-024	23.5	27.5	2
S-025	24.5	28.5	2
S-026	25.5	29.5	2
S-027	26.5	30.5	2
S-028	27.5	31.5	2
S-029	28.5	32.5	2
S-030	29.5	33.5	2
S-31.5	31	35	2
S-032	31.5	35.5	2
S-034	33.5	37.5	2
S-035	34.5	38.5	2
S-35.5	35	39	2
S-036	35.5	39.5	2
S-037	36.5	40.5	2
S-038	37.5	41.5	2
S-039	38.5	42.5	2
S-040	39.5	43.5	2
S-042	41.5	45.5	2

O 環 S 規格	內徑 I.D.	外徑 O.D.	厚度 w
S-044	43.5	47.5	2
S-045	44.5	48.5	2
S-046	45.5	49.5	2
S-048	47.5	51.5	2
S-050	49.5	53.5	2
S-053	52.5	56.5	2
S-055	54.5	58.5	2
S-056	55.5	59.5	2
S-060	59.5	63.5	2
S-063	62.5	66.5	2
S-065	64.5	68.5	2
S-067	66.5	70.5	2
S-070	69.5	73.5	2
S-071	70.5	74.5	2
S-075	74.5	78.5	2
S-080	79.5	83.5	2
S-085	84.5	88.5	2
S-090	89.5	93.5	2
S-095	94.5	98.5	2
S-100	99.5	103.5	2
S-105	104.5	108.5	2
S-110	109.5	113.5	2
S-112	111.5	115.5	2
S-115	114.5	118.5	2
S-120	119.5	123.5	2
S-125	124.5	128.5	2
S-130	129.5	133.5	2
S-132	131.5	135.5	2
S-135	134.5	138.5	2
S-140	139.5	143.5	2
S-145	144.5	148.5	2
S-150	149.5	153.5	2
S-155	154.5	158.5	2
S-160	159.5	163.5	2
S-165	164.5	168.5	2
S-170	169.5	173.5	2
S-175	174.5	178.5	2

專業製造：橡膠 O 環、U 形、V 形、迫緊、膜片、鐵氟龍、橡膠訂作規格外陸續開模中，請歡迎來電洽詢。

此規格材質 NBR90、VT、SE 若有需要需詢問。

O 環 V 規格

V-Type O-Ring Size List

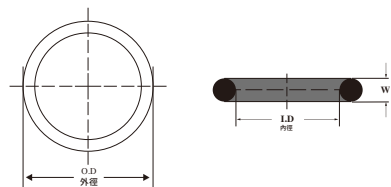

單位 unit : mm

材質	橡膠	橡膠 (高壓)	氟橡膠 (耐熱)	矽橡膠
	NBR70	NBR90	VT	SE

O 環 V 規格	內徑 I.D.	外徑 O.D.	厚度 w
V-85	84	92	4
V-90	89	97	4
V-95	94	102	4
V-100	99	107	4
V-105	104	112	4
V-110	109	117	4
V-115	114	122	4
V-120	119	127	4
V-125	124	132	4
V-130	129	137	4
V-135	134	142	4
V-140	138.5	146.5	4
V-145	143.5	151.5	4
V-150	148.5	156.5	4
V-155	153	161	4
V-160	158	166	4
V-170	168	176	4
V-175	173	181	4
V-180	178	186	4
V-185	183	191	4
V-190	188	196	4
V-195	193	201	4
V-200	198	206	4
V-205	203	211	4
V-210	208	216	4
V-215	213	221	4
V-220	218	226	4
V-225	222.5	234.5	6
V-230	227.5	239.5	6
V-235	232.5	244.5	6
V-240	237.5	249.5	6
V-245	242.5	254.5	6
V-250	247.5	259.5	6
V-255	252.5	264.5	6
V-260	257.5	269.5	6
V-265	262.5	274.5	6
V-270	267.5	279.5	6
V-275	272	284	6

O 環 V 規格	內徑 I.D.	外徑 O.D.	厚度 w
V-280	277	289	6
V-285	282	294	6
V-290	287	299	6
V-295	292	304	6
V-300	297	309	6
V-305	302	314	6
V-310	307	319	6
V-315	312	324	6
V-320	317	329	6
V-325	321.5	333.5	6
V-330	326.5	338.5	6
V-335	331.5	343.5	6
V-340	336.5	348.5	6
V-345	341.5	353.5	6
V-350	346.5	358.5	6
V-355	351.5	363.5	6
V-360	356.5	368.5	6
V-365	361.5	373.5	6
V-370	366.5	378.5	6
V-375	371.5	383.5	6
V-380	376	388	6
V-385	381	393	6
V-390	386	398	6
V-395	391	403	6
V-400	396	408	6
V-405	401	413	6
V-410	406	418	6
V-415	411	423	6
V-420	416	428	6
V-425	421	433	6
V-430	425.5	437.5	6
V-435	430.5	442.5	6
V-445	440.5	452.5	6
V-450	445.5	457.5	6
V-455	450.5	462.5	6
V-460	455.5	467.5	6
V-465	460.5	472.5	6
V-470	465.5	477.5	6

專業製造：橡膠 O 環、U、V 迫緊、膜片、鐵氟龍、橡膠訂作規格外陸續開模中，請歡迎來電洽詢。

此規格材質 NBR90、VT、SE 若有需要需詢問。

O 環線徑 1mm 規格

Metric-Type O-Ring Size List

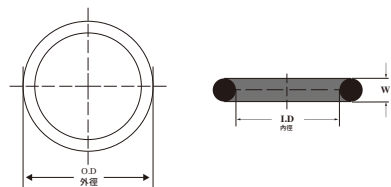

單位 unit : mm

材質	橡膠	橡膠 (高壓)	氟橡膠 (耐熱)	矽橡膠
	NBR70	NBR90	VT	SE

O 環 線徑 1mm 規格	內徑 I.D.	外徑 O.D.	厚度 w
1*1.5	1.5	3.5	1
1*2	2	4	1
1*2.5	2.5	4.5	1
1*2.75	2.75	4.75	1
1*3	3	5	1
1*3.5	3.5	5.5	1
1*4	4	6	1
1*4.5	4.5	6.5	1
1*5	5	7	1
1*5.5	5.5	7.5	1
1*6	6	8	1
1*6.5	6.5	8.5	1
1*7	7	9	1
1*7.5	7.5	9.5	1
1*8	8	10	1
1*9	9	11	1
1*9.5	9.5	11.5	1
1*10	10	12	1
1*11	11	13	1
1*12	12	14	1
1*13	13	15	1
1*14	14	16	1
1*15	15	17	1
1*16	16	18	1
1*17	17	19	1
1*18	18	20	1
1*20	20	22	1
1*21	21	23	1
1*22	22	24	1
1*23	23	25	1
1*24	24	26	1
1*25	25	27	1
1*26	26	28	1
1*28	28	30	1
1*30	30	32	1
1*31	31	33	1
1*32	32	34	1

O 環 線徑 1mm 規格	內徑 I.D.	外徑 O.D.	厚度 w
1*34	34	36	1
1*36	36	38	1
1*37	37	39	1
1*38	38	40	1
1*40	40	42	1
1*42.7	42.7	44.7	1
1*43	43	45	1
1*46	46	48	1
1*47	47	49	1
1*48	48	50	1
1*49	49	51	1
1*50	50	52	1
1*52	52	54	1
1*55	55	57	1
1*60	60	62	1
1*62	62	64	1
1*80	80	82	1
1*96	96	98	1

專業製造：橡膠 O 環、D、V 迫緊、膜片、鐵氟龍、橡膠訂作規格外陸續開模中，請歡迎來電洽詢。

此規格材質 NBR90、VT、SE 若有需要需詢問。

O 環線徑 1.5mm 規格

Metric-Type O-Ring Size List

材質	橡膠	橡膠(高壓)	氟橡膠(耐熱)	矽橡膠
	NBR70	NBR90	VT	SE

單位 unit : mm

O 環 線徑 1.5mm 規格	內徑 I.D.	外徑 O.D.	厚度 w
1.5*1	1	4	1.5
1.5*2	2	5	1.5
1.5*3	3	6	1.5
1.5*4	4	7	1.5
1.5*5	5	8	1.5
1.5*6	6	9	1.5
1.5*7	7	10	1.5
1.5*8	8	11	1.5
1.5*9	9	12	1.5
1.5*10	10	13	1.5
1.5*11	11	14	1.5
1.5*12	12	15	1.5
1.5*13	13	16	1.5
1.5*14	14	17	1.5
1.5*15	15	18	1.5
1.5*16	16	19	1.5
1.5*17	17	20	1.5
1.5*18	18	21	1.5
1.5*19	19	22	1.5
1.5*20	20	23	1.5
1.5*22	22	25	1.5
1.5*22.5	22.5	25.5	1.5
1.5*24	24	27	1.5
1.5*25	25	28	1.5
1.5*27	27	30	1.5
1.5*28	28	31	1.5
1.5*29	29	32	1.5
1.5*29.5	29.5	32.5	1.5
1.5*30	30	33	1.5
1.5*31	31	34	1.5
1.5*32	32	35	1.5
1.5*33	33	36	1.5
1.5*33.5	33.5	36.5	1.5
1.5*34	34	37	1.5
1.5*35	35	38	1.5
1.5*36	36	39	1.5
1.5*38	38	41	1.5

O 環 線徑 1.5mm 規格	內徑 I.D.	外徑 O.D.	厚度 w
1.5*40	40	43	1.5
1.5*44	44	47	1.5
1.5*46	46	49	1.5
1.5*48	48	51	1.5
1.5*49.5	49.5	52.5	1.5
1.5*50	50	53	1.5
1.5*54	54	57	1.5
1.5*55	55	58	1.5
1.5*58	58	61	1.5
1.5*60	60	63	1.5
1.5*62	62	65	1.5
1.5*65	65	68	1.5
1.5*80	80	83	1.5
1.5*100	100	103	1.5

專業製造：橡膠 O 環、J、V 迫緊、膜片、鐵氟龍、橡膠訂作規格外陸續開模中，請歡迎來電洽詢。

此規格材質 NBR90、VT、SE 若有需要需詢問。

O 環線徑 2mm 規格

Metric-Type O-Ring Size List

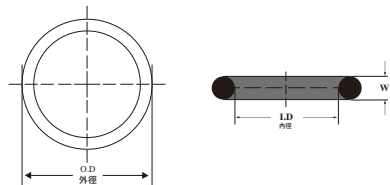

單位 unit : mm

材質	橡膠	橡膠 (高壓)	氟橡膠 (耐熱)	矽橡膠
	NBR70	NBR90	VT	SE

O 環 線徑 2mm 規格	內徑 I.D.	外徑 O.D.	厚度 w
2002	2	6	2
2003	3	7	2
2004	4	8	2
2005	5	9	2
2006	6	10	2
2007	7	11	2
2008	8	12	2
2009	9	13	2
2010	10	14	2
2011	11	15	2
2012	12	16	2
2013	13	17	2
2014	14	18	2
2015	15	19	2
2016	16	20	2
2017	17	21	2
2018	18	22	2
2019	19	23	2
2020	20	24	2
2021	21	25	2
2022	22	26	2
2023	23	27	2
2024	24	28	2
2025	25	29	2
2026	26	30	2
2027	27	31	2
2028	28	32	2
2029	29	33	2
2030	30	34	2
2031	31	35	2
2032	32	36	2
2033	33	37	2
2034	34	38	2
2035	35	39	2
2035.5	35.5	39.5	2
2036	36	40	2
2037	37	41	2

O 環 線徑 2mm 規格	內徑 I.D.	外徑 O.D.	厚度 w
2038	38	42	2
2039	39	43	2
2040	40	44	2
2042	42	46	2
2043	43	47	2
2044	44	48	2
2045	45	49	2
2046	46	50	2
2047	47	51	2
2048	48	52	2
2050	50	54	2
2052	52	56	2
2053	53	57	2
2055	55	59	2
2056	56	60	2
2057	57	61	2
2058	58	62	2
2059	59	63	2
2060	60	64	2
2061	61	65	2
2062	62	66	2
2063	63	67	2
2065	65	69	2
2068	68	72	2
2070	70	74	2
2071	71	75	2
2072	72	76	2
2073	73	77	2
2075	75	79	2
2076	76	80	2
2077	77	81	2
2078	78	82	2
2080	80	84	2
2085	85	89	2
2088	88	92	2
2090	90	94	2
2095	95	99	2

專業製造：橡膠 O 環、U.V 迫緊、膜片、鐵氟龍、橡膠訂作規格外陸續開模中，請歡迎來電洽詢。

此規格材質 NBR90、VT、SE 若有需要需詢問。

O 環線徑 2mm/2.5mm 規格

Metric-Type O-Ring Size List

材質	橡膠	橡膠(高壓)	氟橡膠(耐熱)	矽橡膠
	NBR70	NBR90	VT	SE

單位 unit : mm

O 環 線徑 2mm 規格	內徑 I.D.	外徑 O.D.	厚度 w
2096	96	100	2
2100	100	104	2
2105	105	109	2
2107	107	111	2
2110	110	114	2
2112	112	116	2
2115	115	119	2
2120	120	124	2
2125	125	129	2
2130	130	134	2
2132	132	136	2
2135	135	139	2
2140	140	144	2
2145	145	149	2
2150	150	154	2
2155	155	159	2
2160	160	164	2
2165	165	169	2
2170	170	174	2
2175	175	179	2
2180	180	184	2
2185	185	189	2
2190	190	194	2
2195	195	199	2
2200	200	204	2
2205	205	209	2
2210	210	214	2
2220	220	224	2
2225	225	229	2
2230	230	234	2
2235	235	239	2
2240	240	244	2
2245	245	249	2
2250	250	254	2
2260	260	264	2
2270	270	274	2

O 環 線徑 2.5mm 規格	內徑 I.D.	外徑 O.D.	厚度 w
2.5*3	3	8	2.5
2.5*4	4	9	2.5
2.5*5	5	10	2.5
2.5*6	6	11	2.5
2.5*7	7	12	2.5
2.5*7.5	7.5	12.5	2.5
2.5*8	8	13	2.5
2.5*9	9	14	2.5
2.5*10	10	15	2.5
2.5*11	11	16	2.5
2.5*12	12	17	2.5
2.5*13	13	18	2.5
2.5*14	14	19	2.5
2.5*15	15	20	2.5
2.5*16	16	21	2.5
2.5*17	17	22	2.5
2.5*18	18	23	2.5
2.5*19	19	24	2.5
2.5*20	20	25	2.5
2.5*25	25	30	2.5
2.5*27	27	32	2.5
2.5*28	28	33	2.5
2.5*30	30	35	2.5
2.5*32	32	37	2.5
2.5*40	40	45	2.5
2.5*80	80	85	2.5

專業製造：橡膠 O 環、J、V 迫緊、膜片、鐵氟龍、橡膠訂作規格外陸續開模中，請歡迎來電洽詢。

此規格材質 NBR90、VT、SE 若有需要需詢問。

O 環線徑 3mm 規格

Metric-Type O-Ring Size List

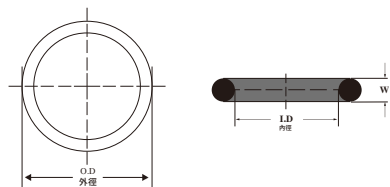

單位 unit : mm

材質	橡膠	橡膠 (高壓)	氟橡膠 (耐熱)	矽橡膠
	NBR70	NBR90	VT	SE

O 環 線徑 3mm 規格	內徑 I.D.	外徑 O.D.	厚度 w
3004	4	10	3
3005	5	11	3
3006	6	12	3
3007	7	13	3
3008	8	14	3
3009	9	15	3
3010	10	16	3
3011	11	17	3
3012	12	18	3
3013	13	19	3
3014	14	20	3
3015	15	21	3
3016	16	22	3
3017	17	23	3
3018	18	24	3
3019	19	25	3
3020	20	26	3
3021	21	27	3
3022	22	28	3
3023	23	29	3
3024	24	30	3
3025	25	31	3
3026	26	32	3
3027	27	33	3
3028	28	34	3
3029	29	35	3
3030	30	36	3
3032	32	38	3
3033	33	39	3
3034	34	40	3
3035	35	41	3
3036	36	42	3
3037	37	43	3
3038	38	44	3
3040	40	46	3
3042	42	48	3
3043	43	49	3

O 環 線徑 3mm 規格	內徑 I.D.	外徑 O.D.	厚度 w
3045	45	51	3
3047	47	53	3
3048	48	54	3
3050	50	56	3
3051	51	57	3
3052	52	58	3
3053	53	59	3
3055	55	61	3
3056	56	62	3
3058	58	64	3
3060	60	66	3
3062	62	68	3
3063	63	69	3
3065	65	71	3
3067	67	73	3
3068	68	74	3
3070	70	76	3
3072	72	78	3
3075	75	81	3
3078	78	84	3
3080	80	86	3
3082	82	88	3
3085	85	91	3
3088	88	94	3
3090	90	96	3
3092	92	98	3
3095	95	101	3
3098	98	104	3
3100	100	106	3
3102	102	108	3
3105	105	111	3
3108	108	114	3
3110	110	116	3
3112	112	118	3
3115	115	121	3
3118	118	124	3
3120	120	126	3

專業製造：橡膠 O 環、U-V 迫緊、膜片、鐵氟龍、橡膠訂作規格外陸續開模中，請歡迎來電洽詢。

此規格材質 NBR90、VT、SE 若有需要需詢問。

O 環線徑 4mm 規格

Metric-Type O-Ring Size List

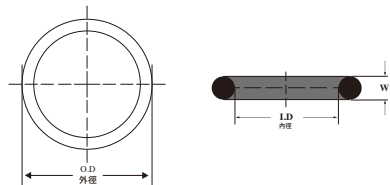

單位 unit : mm

材質	橡膠	橡膠 (高壓)	氟橡膠 (耐熱)	矽橡膠
	NBR70	NBR90	VT	SE

O 環 線徑 4mm 規格	內徑 I.D.	外徑 O.D.	厚度 w
4006	6	14	4
4008	8	16	4
4010	10	18	4
4011	11	19	4
4012	12	20	4
4013	13	21	4
4014	14	22	4
4015	15	23	4
4016	16	24	4
4017	17	25	4
4018	18	26	4
4019	19	27	4
4020	20	28	4
4021	21	29	4
4022	22	30	4
4024	24	32	4
4025	25	33	4
4026	26	34	4
4027	27	35	4
4028	28	36	4
4030	30	38	4
4032	32	40	4
4033	33	41	4
4034	34	42	4
4035	35	43	4
4036	36	44	4
4037	37	45	4
4038	38	46	4
4040	40	48	4
4041	41	49	4
4042	42	50	4
4043	43	51	4
4044	44	52	4
4045	45	53	4
4046	46	54	4
4047	47	55	4

O 環 線徑 4mm 規格	內徑 I.D.	外徑 O.D.	厚度 w
4048	48	56	4
4050	50	58	4
4051	51	59	4
4052	52	60	4
4054	54	62	4
4055	55	63	4
4056	56	64	4
4058	58	66	4
4060	60	68	4
4062	62	70	4
4064	64	72	4
4065	65	73	4
4068	68	76	4
4070	70	78	4
4072	72	80	4
4074	74	82	4
4075	75	83	4
4078	78	86	4
4080	80	88	4
4081	81	89	4
4082	82	90	4
4084	84	92	4
4085	85	93	4
4088	88	96	4
4090	90	98	4
4092	92	100	4
4095	95	103	4
4098	98	106	4
4099	99	107	4
4100	100	108	4
4102	102	110	4
4104	104	112	4
4105	105	113	4
4108	108	116	4
4110	110	118	4
4112	112	120	4

專業製造：橡膠 O 環、U-V 迫緊、膜片、鐵氟龍、橡膠訂作規格外陸續開模中，請歡迎來電洽詢。

此規格材質 NBR90、VT、SE 若有需要需詢問。

O 環線徑 5mm 規格

Metric-Type O-Ring Size List

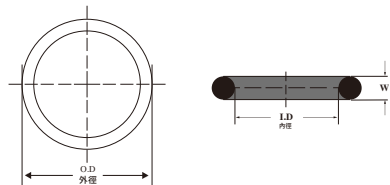

單位 unit : mm

材質	橡膠	橡膠 (高壓)	氟橡膠 (耐熱)	矽橡膠
	NBR70	NBR90	VT	SE

O 環 線徑 5mm 規格	內徑 I.D.	外徑 O.D.	厚度 w
5005	5	15	5
5006	6	16	5
5008	8	18	5
5010	10	20	5
5015	15	25	5
5016	16	26	5
5018	18	28	5
5020	20	30	5
5025	25	35	5
5028	28	38	5
5030	30	40	5
5032	32	42	5
5034	34	44	5
5035	35	45	5
5038	38	48	5
5040	40	50	5
5042	42	52	5
5045	45	55	5
5046	46	56	5
5048	48	58	5
5050	50	60	5
5052	52	62	5
5055	55	65	5
5060	60	70	5
5065	65	75	5
5070	70	80	5
5075	75	85	5
5080	80	90	5
5085	85	95	5
5090	90	100	5
5095	95	105	5
5100	100	110	5
5102	102	112	5
5105	105	115	5
5110	110	120	5
5115	115	125	5
5120	120	130	5

O 環 線徑 5mm 規格	內徑 I.D.	外徑 O.D.	厚度 w
5125	125	135	5
5130	130	140	5
5135	135	145	5
5140	140	150	5
5145	145	155	5
5150	150	160	5
5155	155	165	5
5160	160	170	5
5165	165	175	5
5170	170	180	5
5175	175	185	5
5180	180	190	5
5185	185	195	5
5190	190	200	5
5195	195	205	5
5200	200	210	5
5205	205	215	5
5210	210	220	5
5215	215	225	5
5220	220	230	5
5225	225	235	5
5230	230	240	5
5240	240	250	5
5245	245	255	5
5250	250	260	5
5255	255	265	5
5260	260	270	5
5265	265	275	5
5270	270	280	5
5280	280	290	5
5285	285	295	5
5290	290	300	5
5295	295	305	5
5300	300	310	5
5320	320	330	5
5325	325	335	5

專業製造：橡膠 O 環、U-V 迫緊、膜片、鐵氟龍、橡膠訂作規格外陸續開模中，請歡迎來電洽詢。

此規格材質 NBR90、VT、SE 若有需要需詢問。

O 環 JASO F404 規格

JASO F404-Type O-Ring Size List

材質	橡膠	橡膠 (高壓)	氟橡膠 (耐熱)	矽橡膠
	NBR70	NBR90	VT	SE

單位 unit : mm

O 環 JASO 規格	內徑 I.D.	外徑 O.D.	厚度 w
1003	2.8	6.6	1.9
1004	3.8	7.6	1.9
1005	4.8	8.6	1.9
1006	5.8	9.6	1.9
1007	6.8	10.6	1.9
1008	7.8	11.6	1.9
1009	8.8	12.6	1.9
1010	9.8	13.6	1.9
1011	11	14.8	1.9
1012	12.3	16.1	1.9
1013	13	16.8	1.9
1014	13.8	17.6	1.9
1015	14.8	18.6	1.9
1016	15.8	19.6	1.9
1017	16.8	20.6	1.9
1018	17.8	21.6	1.9
1019	18.8	22.6	1.9
1020	19.8	23.6	1.9
1021	21	24.8	1.9
1022	22.1	25.9	1.9
1023	23.3	27.1	1.9
1025	24.7	28.5	1.9
1026	26.2	30	1.9
1028	27.7	31.5	1.9
1030	29.7	33.5	1.9
1031	31.2	35	1.9
1033	33.2	37	1.9
1035	35.2	39	1.9

O 環 JASO 規格	內徑 I.D.	外徑 O.D.	厚度 w
1010A	9.8	14.6	2.4
111.2	11	15.8	2.4
112.5	12.3	17.1	2.4
92013	13	17.8	2.4
10014	13.8	18.6	2.4
10015	14.8	19.6	2.4
10016	15.8	20.6	2.4
92017	16.8	21.6	2.4
10018	17.8	22.6	2.4
92019	18.8	23.6	2.4
10020	19.8	24.6	2.4
10021	20.8	25.6	2.4
92022	22.1	26.9	2.4
92023	23.3	28.1	2.4
92025	24.7	29.5	2.4
92026	26.2	31	2.4
92028	27.7	32.5	2.4
92030	29.7	34.5	2.4
92031	31.2	36	2.4
92033	33.2	38	2.4
92035	35.2	40	2.4
92037	37.2	42	2.4
92040	39.7	44.5	2.4
92042	42.2	47	2.4
92045	44.7	49.5	2.4
92047	47.2	52	2.4
92050	49.7	54.5	2.4
92053	52.6	57.4	2.4
92056	55.6	60.4	2.4
92060	59.6	64.4	2.4
92063	62.6	67.4	2.4
92067	66.6	71.4	2.4
92071	70.6	75.4	2.4

專業製造：橡膠 O 環、U、V、迫緊、膜片、鐵氟龍、橡膠訂作規格外陸續開模中，請歡迎來電洽詢。

此規格材質 NBR90、VT、SE 若有需要需詢問。

X 型環

X-Ring Size List



材質	橡膠	橡膠(高壓)	氟橡膠(耐熱)	矽橡膠
	NBR70	NBR90	VT	SE

單位 unit : mm

X 環規格	內徑 I.D.	外徑 O.D.	厚度 w
X-4004	1.78	5.34	1.78
X-4005	2.57	6.13	1.78
X-4006	2.9	6.46	1.78
X-4007	3.69	7.25	1.78
X-4008	4.47	8.03	1.78
X-4009	5.29	8.85	1.78
X-4010	6.07	9.63	1.78
X-4011	7.65	11.21	1.78
X-4012	9.25	12.81	1.78
X-4013	10.82	14.38	1.78
X-4014	12.42	15.98	1.78
X-4015	14	17.56	1.78
X-4016	15.6	19.16	1.78
X-4017	17.17	20.73	1.78
X-4018	18.77	22.33	1.78
X-4019	20.35	23.91	1.78
X-4020	21.95	25.51	1.78
X-4021	23.52	27.08	1.78
X-4022	25.12	28.68	1.78
X-4023	26.7	30.26	1.78
X-4024	28.3	31.86	1.78
X-4025	29.87	33.43	1.78
X-4026	31.47	35.03	1.78
X-4027	33.05	36.61	1.78
X-4028	34.65	38.21	1.78
X-4029	37.82	41.38	1.78
X-4030	41	44.56	1.78
X-4031	44.17	47.73	1.78
X-4032	47.35	50.91	1.78
X-4033	50.52	54.08	1.78
X-4034	53.7	57.26	1.78
X-4035	56.87	60.43	1.78
X-4036	60.04	63.6	1.78
X-4037	63.22	66.78	1.78
X-4038	66.4	69.96	1.78
X-4039	69.57	73.13	1.78
X-4040	72.75	76.31	1.78

X 環規格	內徑 I.D.	外徑 O.D.	厚度 w
X-4041	75.92	79.48	1.78
X-4042	82.27	85.83	1.78
X-4043	88.62	92.18	1.78
X-4044	94.97	98.53	1.78
X-4045	101.32	104.88	1.78
X-4046	107.62	111.18	1.78
X-4047	114.02	117.58	1.78
X-4048	120.37	123.93	1.78
X-4049	126.72	130.28	1.78
X-4050	133.07	136.63	1.78
X-4103	2.05	7.29	2.62
X-4104	2.84	8.08	2.62
X-4105	3.63	8.87	2.62
X-4106	4.42	9.66	2.62
X-4107	5.23	10.47	2.62
X-4108	6.02	11.26	2.62
X-4109	7.6	12.84	2.62
X-4110	9.19	14.43	2.62
X-4111	10.77	16.01	2.62
X-4112	12.37	17.61	2.62
X-4113	13.95	19.19	2.62
X-4114	15.54	20.78	2.62
X-4115	17.12	22.36	2.62
X-4116	18.72	23.96	2.62
X-4117	20.29	25.53	2.62
X-4118	21.9	27.14	2.62
X-4119	23.47	28.71	2.62
X-4120	25.07	30.31	2.62
X-4121	26.65	31.89	2.62
X-4122	28.25	33.49	2.62
X-4123	29.82	35.06	2.62
X-4124	31.42	36.66	2.62
X-4125	32.99	38.23	2.62
X-4126	34.6	39.84	2.62

專業製造：橡膠 O 環、U、V 迫緊、膜片、鐵氟龍、橡膠訂作規格外陸續開模中，請歡迎來電洽詢。

此規格材質 NBR90、VT、SE 若有需要需詢問。

X 型環

X-Ring Size List

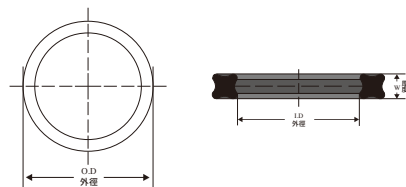

單位 unit : mm

材質	橡膠	橡膠 (高壓)	氟橡膠 (耐熱)	矽橡膠
	NBR70	NBR90	VT	SE

X 環規格	內徑 I.D.	外徑 O.D.	厚度 w
X-4127	36.17	41.41	2.62
X-4128	37.77	43.01	2.62
X-4129	39.35	44.59	2.62
X-4130	40.95	46.19	2.62
X-4131	42.52	47.76	2.62
X-4132	44.12	49.36	2.62
X-4133	45.7	50.94	2.62
X-4134	47.3	52.54	2.62
X-4135	48.9	54.14	2.62
X-4136	50.47	55.71	2.62
X-4137	52.07	57.31	2.62
X-4138	53.65	58.89	2.62
X-4139	55.25	60.49	2.62
X-4140	56.82	62.06	2.62
X-4141	58.42	63.66	2.62
X-4142	60	65.24	2.62
X-4143	61.6	66.84	2.62
X-4144	63.17	68.41	2.62
X-4145	64.77	70.01	2.62
X-4146	66.35	71.59	2.62
X-4147	67.95	73.19	2.62
X-4148	69.52	74.76	2.62
X-4149	71.12	76.36	2.62
X-4150	72.7	77.94	2.62
X-4151	75.87	81.11	2.62
X-4152	82.22	87.46	2.62
X-4153	88.57	93.81	2.62
X-4154	94.92	100.16	2.62
X-4155	101.27	106.51	2.62
X-4156	107.62	112.86	2.62
X-4157	113.97	119.21	2.62
X-4158	120.32	125.56	2.62
X-4159	126.67	131.91	2.62
X-4160	133.02	138.26	2.62
X-4161	139.37	144.61	2.62
X-4162	145.72	150.96	2.62
X-4163	152.07	157.31	2.62

X 環規格	內徑 I.D.	外徑 O.D.	厚度 w
X-4164	158.42	163.66	2.62
X-4165	164.77	170.01	2.62
X-4166	171.12	176.36	2.62
X-4167	177.47	182.71	2.62
X-4168	183.82	189.06	2.62
X-4169	190.17	195.41	2.62
X-4170	196.52	201.76	2.62
X-4204	9.12	16.18	3.53
X-4205	10.69	17.75	3.53
X-4206	12.29	19.35	3.53
X-4207	13.87	20.93	3.53
X-4208	15.47	22.53	3.53
X-4209	17.04	24.1	3.53
X-4210	18.64	25.7	3.53
X-4211	20.22	27.28	3.53
X-4212	21.82	28.88	3.53
X-4213	23.4	30.46	3.53
X-4214	25	32.06	3.53
X-4215	26.57	33.63	3.53
X-4216	28.17	35.23	3.53
X-4217	29.75	36.81	3.53
X-4218	31.34	38.4	3.53
X-4219	32.92	39.98	3.53
X-4220	34.52	41.58	3.53
X-4221	36.1	43.16	3.53
X-4222	37.7	44.76	3.53
X-4223	40.87	47.93	3.53
X-4224	44.05	51.11	3.53
X-4225	47.22	54.28	3.53
X-4226	50.4	57.46	3.53
X-4227	53.57	60.63	3.53
X-4228	56.75	63.81	3.53
X-4229	59.92	66.98	3.53
X-4230	63.1	70.16	3.53

專業製造：橡膠 O 環、U 型 V 迫緊、膜片、鐵氟龍、橡膠訂作規格外陸續開模中，請歡迎來電洽詢。

此規格材質 NBR90、VT、SE 若有需要需詢問。

X 型環

X-Ring Size List



材質	橡膠	橡膠(高壓)	氟橡膠(耐熱)	矽橡膠
	NBR70	NBR90	VT	SE

單位 unit : mm

X 環規格	內徑 I.D.	外徑 O.D.	厚度 w
X-4231	66.27	73.33	3.53
X-4232	69.44	76.5	3.53
X-4233	72.62	79.68	3.53
X-4234	75.79	82.85	3.53
X-4235	78.97	86.03	3.53
X-4236	82.14	89.2	3.53
X-4237	85.32	92.38	3.53
X-4238	88.49	95.55	3.53
X-4239	91.67	98.73	3.53
X-4240	94.84	101.9	3.53
X-4241	98.02	105.08	3.53
X-4242	101.19	108.25	3.53
X-4243	104.37	111.43	3.53
X-4244	107.54	114.6	3.53
X-4245	110.72	117.78	3.53
X-4246	113.89	120.95	3.53
X-4247	117.07	124.13	3.53
X-4248	120.24	127.3	3.53
X-4249	123.42	130.48	3.53
X-4250	126.59	133.65	3.53
X-4251	129.77	136.83	3.53
X-4252	132.94	140	3.53
X-4253	136.12	143.18	3.53
X-4254	139.3	146.36	3.53
X-4255	142.47	149.53	3.53
X-4256	145.65	152.71	3.53
X-4257	148.82	155.88	3.53
X-4258	152	159.06	3.53
X-4259	158.35	165.41	3.53
X-4260	164.7	171.76	3.53
X-4261	171.05	178.11	3.53
X-4262	177.4	184.46	3.53
X-4263	183.75	190.81	3.53
X-4264	190.1	197.16	3.53
X-4265	196.45	203.51	3.53
X-4266	202.8	209.86	3.53
X-4267	209.15	216.21	3.53

X 環規格	內徑 I.D.	外徑 O.D.	厚度 w
X-4268	215.5	222.56	3.53
X-4269	221.85	228.91	3.53
X-4270	228.2	235.26	3.53
X-4271	234.55	241.61	3.53
X-4272	240.9	247.96	3.53
X-4273	247.25	254.31	3.53
X-4274	253.6	260.66	3.53
X-4275	266.3	273.36	3.53
X-4276	279	286.06	3.53
X-4312	15.24	25.9	5.33
X-4313	16.81	27.47	5.33
X-4314	18.42	29.08	5.33
X-4315	19.99	30.65	5.33
X-4316	21.59	32.25	5.33
X-4317	23.16	33.82	5.33
X-4318	24.77	35.43	5.33
X-4319	26.34	37	5.33
X-4320	27.94	38.6	5.33
X-4321	29.51	40.17	5.33
X-4322	31.12	41.78	5.33
X-4323	32.69	43.35	5.33
X-4324	34.29	44.95	5.33
X-4325	37.47	48.13	5.33
X-4326	40.65	51.31	5.33
X-4327	43.82	54.48	5.33
X-4328	46.99	57.65	5.33
X-4329	50.16	60.82	5.33
X-4330	53.34	64	5.33
X-4331	56.52	67.18	5.33
X-4332	59.69	70.35	5.33
X-4333	62.87	73.53	5.33
X-4334	66.04	76.7	5.33
X-4335	69.22	79.88	5.33
X-4336	72.39	83.05	5.33

專業製造：橡膠 O 環、U、V 迫緊、膜片、鐵氟龍、橡膠訂作規格外陸續開模中，請歡迎來電洽詢。

此規格材質 NBR90、VT、SE 若有需要需詢問。

X 型環

X-Ring Size List

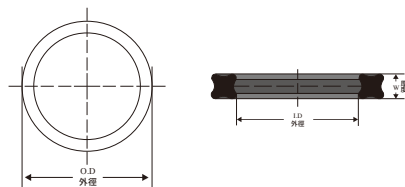

單位 unit : mm

材質	橡膠	橡膠 (高壓)	氟橡膠 (耐熱)	矽橡膠
	NBR70	NBR90	VT	SE

X 環規格	內徑 I.D.	外徑 O.D.	厚度 w
X-4337	75.57	86.23	5.33
X-4338	78.74	89.4	5.33
X-4339	81.92	92.58	5.33
X-4340	85.09	95.75	5.33
X-4341	88.27	98.93	5.33
X-4342	91.44	102.1	5.33
X-4343	94.62	105.28	5.33
X-4344	97.79	108.45	5.33
X-4345	100.96	111.62	5.33
X-4346	104.14	114.8	5.33
X-4347	107.32	117.98	5.33
X-4348	110.49	121.15	5.33
X-4349	113.67	124.33	5.33
X-4350	116.84	127.5	5.33
X-4351	120.02	130.68	5.33
X-4352	123.19	133.85	5.33
X-4353	126.37	137.03	5.33
X-4354	129.54	140.2	5.33
X-4355	132.72	143.38	5.33
X-4356	135.89	146.55	5.33
X-4357	139.07	149.73	5.33
X-4358	142.24	152.9	5.33
X-4359	145.42	156.08	5.33
X-4360	148.59	159.25	5.33
X-4361	151.77	162.43	5.33
X-4362	158.12	168.78	5.33
X-4363	164.47	175.13	5.33
X-4364	170.82	181.48	5.33
X-4365	177.17	187.83	5.33
X-4366	183.52	194.18	5.33
X-4367	189.87	200.53	5.33
X-4368	196.22	206.88	5.33
X-4369	202.57	213.23	5.33
X-4370	208.92	219.58	5.33
X-4371	215.27	225.93	5.33
X-4372	221.62	232.28	5.33
X-4373	227.97	238.63	5.33

X 環規格	內徑 I.D.	外徑 O.D.	厚度 w
X-4374	234.32	244.98	5.33
X-4375	240.67	251.33	5.33
X-4376	247.02	257.68	5.33
X-4377	253.37	264.03	5.33
X-4378	266.07	276.73	5.33
X-4379	278.77	289.43	5.33
X-4380	291.47	302.13	5.33
X-4381	304.17	314.83	5.33
X-4382	329.55	340.21	5.33
X-4383	354.97	365.63	5.33
X-4425	113.67	127.65	6.99
X-4426	116.84	130.82	6.99
X-4427	120.02	134	6.99
X-4428	123.19	137.17	6.99
X-4429	126.37	140.35	6.99
X-4430	129.54	143.52	6.99
X-4431	132.72	146.7	6.99
X-4432	135.89	149.87	6.99
X-4433	139.07	153.05	6.99
X-4434	142.24	156.22	6.99
X-4435	145.42	159.4	6.99
X-4436	148.59	162.57	6.99
X-4437	151.77	165.75	6.99
X-4438	158.12	172.1	6.99
X-4439	164.47	178.45	6.99
X-4440	170.82	184.8	6.99
X-4441	177.17	191.15	6.99
X-4442	183.52	197.5	6.99
X-4443	189.87	203.85	6.99
X-4444	196.22	210.2	6.99
X-4445	202.57	216.55	6.99
X-4446	215.27	229.25	6.99
X-4447	227.97	241.95	6.99
X-4448	240.67	254.65	6.99

專業製造：橡膠 O 環、U 型、V 型、迫緊、膜片、鐵氟龍、橡膠訂作規格外陸續開模中，請歡迎來電洽詢。

此規格材質 NBR90、VT、SE 若有需要需詢問。